

CREATING POWER SOLUTIONS.



1B20 | 1B27 | 1B30 | 1B40 | 1B50

## OPERATOR'S MANUAL Diesel engine

**Hatz Diesel**

0000 433 802 10 - 01.2013 - 3

Printed in Germany

ENG

[www.HATZ-DIESEL.com](http://www.HATZ-DIESEL.com)



<b>1</b>	<b>Notices .....</b>	<b>5</b>
<b>2</b>	<b>General information .....</b>	<b>6</b>
<b>3</b>	<b>Safety .....</b>	<b>7</b>
3.1	General information .....	7
3.1.1	Intended use and foreseeable misuse .....	7
3.1.2	Machine user or machine manufacturer obligations .....	8
3.1.3	Representation of safety notes .....	9
3.1.4	Meaning of safety symbols .....	10
3.2	Safety notes .....	11
3.2.1	Operational safety .....	11
3.2.2	Machine-specific safety instructions for operation .....	14
3.2.3	Machine-specific safety instructions for maintenance work .....	16
3.2.4	Electrical equipment .....	18
3.3	Labels .....	19
<b>4</b>	<b>Technical data .....</b>	<b>23</b>
4.1	Engine .....	23
4.2	Fuel .....	24
4.3	Engine oil .....	24
<b>5</b>	<b>Engine design .....</b>	<b>26</b>
<b>6</b>	<b>Transport, assembly and commissioning .....</b>	<b>28</b>
6.1	Transport .....	28
6.2	Assembly instructions .....	28
6.3	Preparations for commissioning .....	29
<b>7</b>	<b>Operation and use .....</b>	<b>30</b>
7.1	Safety notes .....	30
7.2	Performing tests .....	31
7.3	Setting the speed control .....	32
7.4	Starting the engine .....	32
7.4.1	Starting the engine with recoil start (up to -6 °C) .....	33
7.4.2	Starting the engine with an electric starter .....	35
7.5	Switching off the engine .....	37
7.5.1	Switching off the engine (mechanical) .....	37
7.5.2	Switching off the engine (electrical) .....	39
7.6	Refueling .....	40
7.7	Checking the water separator .....	43
7.8	Checking the oil level and adding oil if necessary .....	44
7.8.1	Engine oil level .....	45
7.8.2	Oil level in the oil bath filter (option) .....	46

<b>8</b>	<b>Maintenance .....</b>	<b>47</b>
8.1	General maintenance instructions .....	47
8.2	Maintenance work .....	48
8.2.1	Maintenance notice label .....	48
8.2.2	Maintenance plan .....	49
8.2.3	Checking the intake area .....	51
8.2.4	Change the engine oil .....	53
8.2.5	Clean the oil filter .....	54
8.2.6	Check and set the tappet clearance .....	56
8.2.7	Maintaining the oil bath filter .....	60
8.2.8	Clean the cooling air area .....	61
8.2.9	Check the screw connections .....	64
8.2.10	Clean the exhaust screen .....	64
8.2.11	Changing the fuel filter .....	68
8.2.12	Maintaining the dry air filter .....	73
8.2.13	Checking and cleaning the air filter cartridge .....	75
<b>9</b>	<b>Faults .....</b>	<b>77</b>
9.1	Troubleshooting .....	77
9.2	Emergency start .....	83
<b>10</b>	<b>Storage and disposal .....</b>	<b>86</b>
10.1	Storing the machine .....	86
10.2	Disposing of the machine .....	86
<b>11</b>	<b>Installation declaration .....</b>	<b>87</b>

# 1 Notices

## Contact data

© 2012  
Motorenfabrik HATZ  
Ernst-Hatz-Straße 16  
94099 Ruhstorf  
Germany  
Tel. +49 (0)8531 319-0  
Fax +49 (0)8531 319-418  
marketing@hatz-diesel.de  
www.hatz-diesel.com  
All rights reserved!

## Copyright

The copyright for this Operator's Manual rests entirely with Motorenfabrik HATZ, Ruhstorf.

This Operator's Manual may only be copied or distributed if written approval has been received. This also applies to the copying or distribution of excerpts of the Operator's Manual. The same conditions apply to distribution of the Operator's Manual to third parties in digital form.

## Original Operator's Manual

This Operator's Manual was translated into multiple languages.

The German version is the **original Operator's Manual**. All other language versions are **translations** of the **original Operator's Manual**.

## 2 General information

### Information on the document

This Operator's Manual was created with due care. It is exclusively intended to offer a technical description of the machine and to provide instructions on commissioning, operating and maintaining the machine. When operating the machine, the applicable standards and legal regulations as well as any in-house regulations apply.

Before commissioning, during operation and before maintenance work is begun on the machine, read the Operator's Manual carefully and keep it close by for ready access.

### Machine

This Operator's Manual describes the following machine.

Machine name	HATZ diesel engine
Type number	1B20, 1B27, 1B30, 1B40, 1B50

### Customer service

Have service work performed by qualified technicians only. We recommend that you work with one of the over 500 **HATZ service stations**. Trained specialists there will repair your machine with **Hatz original spare parts** and with **HATZ tools**. The global HATZ service network is at your disposal to advise you and supply you with spare parts. For the address of the **Hatz service station** nearest you, please see the directory included or visit the Internet at: **www.hatz-diesel.com**

Problems may occur if unsuitable spare parts are installed. We cannot accept responsibility for damage and secondary damage that result from this.

We therefore recommend the use of **Hatz original spare parts**. These parts are manufactured according to strict Hatz specifications and achieve maximum operational reliability through their perfect fit and functionality. The order number can be found in the included spare parts list or on the Internet at: **www.hatz-diesel.com**

### Exclusion of liability

The manufacturer cannot be held responsible for personal injury, damage to property, or damage to the machine itself caused by improper use, foreseeable misuse or failure to follow or adequately follow the safety measures and procedures described in this Operator's Manual. This also applies to changes made to the machine and use of unsuitable spare parts.

We reserve the right to make modifications in the interest of technical improvement.

## 3 Safety

### 3.1 General information

#### Introduction

This chapter contains the information you need to work safely with this machine.

To prevent accidents and damage to the machine, it is imperative that these safety instructions be followed.

Read this chapter carefully before beginning work.

#### 3.1.1 Intended use and foreseeable misuse

##### Intended use

The machine described in this Operator's Manual fulfills the following functions:

- Diesel engine intended for installation in a machine or for assembly with other machines to form a machine. See the chapter *11 Installation declaration, page 87*.

This engine is intended exclusively for the purpose specified and tested by the manufacturer of the machine into which the engine is installed.

Any other use is not intended and therefore not permitted. Violations compromise the safety of the personnel working with the machine. Responsibility is not accepted by Motorenfabrik HATZ for damage resulting from this situation.

The operational safety of the machine is only guaranteed if it is used as intended.

Use according to the intended purpose also includes observance of the instructions in this Operator's Manual.

##### Foreseeable misuse

The following is considered to be foreseeable misuse:

- Any use that varies from or extends beyond the uses specified above.
- Failure to comply with the instructions in this Operator's Manual.
- Failure to comply with the safety instructions.
- Failure to immediately eliminate malfunctions that impact safety before continuing work with the machine (working with the machine when it is not in perfect condition, either functionally or in terms of safety).
- Failure to perform the necessary inspection and maintenance work.
- Any unauthorized modification of or removal of safety equipment.
- Use of spare parts and accessories that are unsuitable or have not been approved by HATZ.
- Operation in flammable or hazardous environments.
- Operation in closed-off or poorly ventilated rooms.

- Installation of the machine in moving equipment (e.g. vehicles, trailers) or in closed rooms without additional measures to handle supply air, extract air and exhaust.
- Improper operation at variance with DIN 6271 and DIN ISO 8528 (climate, load, safety).

### Residual risks

Residual risks result during daily use and in association with maintenance work.

These residual risks are described in the chapter 3.2.2 *Machine-specific safety instructions for operation, page 14* and in the chapter 3.2.3 *Machine-specific safety instructions for maintenance work, page 16*, and in other parts of the manual directly preceding the affected descriptions and instructions.

## 3.1.2 Machine user or machine manufacturer obligations

### Machine manufacturer obligations

If you have an engine that is not yet installed in a machine, it is imperative that you follow the **Assembly Instructions for HATZ Diesel Engines** before installing the engine. These assembly instructions contain important information on how to safely install the engine and are available at your nearest **HATZ service station**.

**It is prohibited to start the engine before it is fully installed.**

In addition, please note that it is prohibited to start up the machine before it has been determined that the machine into which this engine is installed fulfills all safety-related requirements and legal regulations.

### User obligations

The user is obligated to only operate the machine while it is in perfect condition. The user must check the condition of the machine before using it and ensure that any defects are eliminated before it is taken into service. Operation of the machine while identified defects exist is not permitted. The user must also ensure that the information contained in the Operator's Manual has been read and understood.

### Obligations of the operating and maintenance personnel

Personnel assigned with operating and maintaining the machine must have read and understood the Operator's Manual or must be able to demonstrate the necessary qualifications for working with this equipment, acquired in training/instructional courses. No one may work with the machine without the necessary qualifications, even if for just a brief period.

All work performed on the machine must be in compliance with the information provided in the Operator's Manual.



## Storing the Operator's Manual

This Operator's Manual is an integral component of the machine (also when being sold). It must be stored in the direct vicinity of the machine and be accessible to personnel at all times.

### 3.1.3 Representation of safety notes

#### Overview

This machine has been designed and built according to state-of-the-art technology and the recognized safety standards. Despite these precautions, risks exist when operating the machine and during maintenance work.

These risks are identified in this manual by means of safety notes.

The safety notes precede the related description or operating step.

#### Structure of the safety notes

The safety notes consist of:

- Warning symbol
- Signal word
- Description of danger
- Possible consequences
- Preventative measures



#### General danger symbol



The general danger symbol is used to identify the danger of personal injury.

#### Signal words

Signal words identify the magnitude of the risk and the seriousness of the possible injuries:







Warning symbol/ Signal word	Meaning
 <b>DANGER</b>	This signal word is used to indicate imminently dangerous situations which, if not avoided, will lead to serious injury or death.
 <b>WARNING</b>	This signal word is used to indicate potentially dangerous situations which, if not avoided, may lead to serious injury or death.
 <b>CAUTION</b>	This signal word is used to indicate potentially dangerous situations which, if not avoided, may lead to minor or moderate injury.





Warning symbol/ Signal word	Meaning
<b>CAUTION</b>	This signal word, without a danger symbol, is used to indicate the risk of property damage.
<b>NOTICE</b>	This signal word indicates additional useful information, such as operating tips and cross references.

### 3.1.4 Meaning of safety symbols

#### Explanation of symbols

The following table describes the meanings of the safety symbols used in this Operator's Manual.

Symbol	Meaning
	Smoking, fire and open flames are prohibited.
	Warning of personal injury!
	Warning of hot surfaces!
	Warning of flammable substances!
	Warning of explosive substances!
	Warning of toxic engine exhaust!
	Warning of corrosive substances!



Symbol	Meaning
	Warning of heavy loads!
	Warning of environmental damage!
	Comply with the Operator's Manual or additional documentation from other manufacturers or the user.
	Additional information that is useful to the reader.

## 3.2 Safety notes

### 3.2.1 Operational safety

#### Introduction

This chapter contains all of the important safety instructions for personal protection and for safe and reliable operation. Additional, task-related safety instructions can be found at the beginning of each chapter.

 <b>DANGER</b>	
	<p><b>Danger to life, danger of injury or danger of property damage due to failure to comply with the Operator's Manual and the safety instructions contained therein.</b></p> <ul style="list-style-type: none"> <li>▪ As the user of the machine, you must ensure that all people working on the machine are familiar with the content of this Operator's Manual.</li> <li>▪ Before working on the machine, read this Operator's Manual carefully, paying special attention to the safety notes.</li> <li>▪ Fulfill all required safety conditions before working on the machine.</li> <li>▪ Follow all general safety instructions as well as the specific task-related safety instructions contained in the individual chapters.</li> </ul>

### Using the machine

- Only operate the machine for the purposes described in the chapter 3.1.1 *Intended use and foreseeable misuse*, page 7.

### Compliance with other regulations

- Adhere to the applicable accident prevention regulations of the trade associations.
- Comply with the regulations concerning the minimum safety and health requirements for the use of work equipment by workers at work.
- In addition, local safety, accident prevention and environmental regulations also apply when operating the machine.



### Operating personnel

- The machine may only be operated by qualified personnel. The personnel must have read and understood this Operator's Manual or must be able to demonstrate the necessary qualifications for working with this equipment, acquired in training/instructional courses.
- The operating personnel must not be under the influence of drugs, medication or alcohol.

### Personal protective equipment

During operation and maintenance of the machine, personal protective equipment must be available and must be used if necessary. The required personal protective equipment is specified in the descriptions of the operating steps.

Personal protective equipment	Pictogram	Function
Safety shoes		Safety shoes offer protection against: <ul style="list-style-type: none"> <li>▪ Slipping</li> <li>▪ Falling objects</li> </ul>
Hearing protection		Hearing protection offers protection against ear injuries due to excessive and constant noise.
Safety gloves		Safety gloves protect the hands against injury, for example from battery acid.

Personal protective equipment	Pictogram	Function
Safety goggles (with side shields)		Safety goggles protect the eyes from flying objects (for example, dust particles, spraying liquids, spraying acid).
Working clothes		Wear close-fitting clothing. However, it must not restrict the wearer's freedom of movement.

### Warning and notice labels on the machine

The warning and notice labels on the machine must be followed (see the chapter 3.3 *Labels*, page 19).

The warning and notice labels must be kept legible and must be replaced if necessary. For this purpose, contact your nearest **HATZ service station**.

### Maintenance work



Maintenance work that goes beyond the scope described in this manual must only be performed by qualified technicians (see the chapter 2 *General information*, page 6).







Independent maintenance work and constructional changes to the machine, especially to the safety equipment, are not permitted.

### Safety equipment

Safety equipment must not be modified and must not be rendered ineffective during normal operation.

### General safety notes

 <b>DANGER</b>	
	<p><b>Danger to life and danger of injury due to failure to follow the warnings on the machine and in the Operator's Manual.</b></p> <ul style="list-style-type: none"> <li>▪ Heed the warnings on the machine and in the Operator's Manual.</li> </ul>

 <b>WARNING</b>	
	<p><b>Danger of injury and danger of incorrect operation due to inadequate personnel qualifications.</b></p> <ul style="list-style-type: none"> <li>▪ The personnel must have read and understood this Operator's Manual or must be able to demonstrate the necessary qualifications for working with this equipment, acquired in training/instructional courses.</li> <li>▪ Only qualified personnel is permitted to operate and maintain this machine.</li> <li>▪ Failure to comply will cause the warranty to be void.</li> </ul>
 <b>WARNING</b>	
	<p><b>Danger of injury from the failure to follow the operating instructions and from performing unauthorized tasks on the machine.</b></p> <ul style="list-style-type: none"> <li>▪ Follow all instructions.</li> <li>▪ Do not perform activities that are not authorized. Contact properly trained personnel if necessary.</li> </ul>
 <b>CAUTION</b>	
	<p><b>Danger of injury from overloading the body.</b></p> <p>Lifting the machine to transport it or to move it to another location can lead to injuries (of the back, for example).</p> <ul style="list-style-type: none"> <li>▪ Only lift the machine with a hoist (see the chapter 6.1 <i>Transport, page 28</i>).</li> </ul>

## 3.2.2 Machine-specific safety instructions for operation

### Introduction

The machine can pose residual risks during operation. To eliminate these risks, all persons working on the machine must follow the general and machine-specific safety instructions.

If you have an engine that is not yet installed in a machine, it is imperative that you follow the **Assembly Instructions for HATZ Diesel Engines** before installing the engine.

These assembly instructions contain important information on safe installation.

If the engine is installed in a machine or assembled with other machines to form a machine, it is prohibited to start the engine before it has been determined that the newly created machine fulfills all safety-related requirements and applicable legal regulations .



### Safe operation

- Before switching on the machine, ensure that no one can be injured when the machine is started up.
- During machine operation, ensure that unauthorized persons do not have access to the area in which the machine has an impact.
- Parts of the exhaust gas system and the surface of the engine become hot during operation. Risk of injury from touching hot parts! Let the engine cool before maintenance.
- Do not refuel during operation.

### Faults

- Immediately eliminate faults that compromise safety.
- Switch off the machine and do not take into service again until all faults have been eliminated.

### Safety instructions for operation

 <b>DANGER</b>	
	<p><b>Danger to life from inhaling exhaust gases.</b></p> <p>Toxic engine exhaust gases can lead to loss of consciousness and even death in closed-off and poorly ventilated rooms.</p> <ul style="list-style-type: none"> <li>▪ Never operate the machine in closed-off or poorly ventilated rooms.</li> <li>▪ Do not breathe in the exhaust gases.</li> </ul>
 <b>DANGER</b>	
 	<p><b>Fire hazard from fuel.</b></p> <p>Leaked or spilled fuel can ignite on hot engine parts and cause serious burn injuries.</p> <ul style="list-style-type: none"> <li>▪ Only refuel while the engine is switched off.</li> <li>▪ Never refuel in the vicinity of open flames or sparks that can cause ignition.</li> <li>▪ Do not smoke.</li> <li>▪ Do not spill fuel.</li> </ul>
 <b>CAUTION</b>	
	<p><b>Danger of injury from faulty starter rope.</b></p> <p>A chafed starter rope can rip and cause injuries.</p> <ul style="list-style-type: none"> <li>▪ Before using the starter rope, check for abrasion; replace the rope if necessary.</li> </ul>

### 3.2.3 Machine-specific safety instructions for maintenance work

#### Introduction

The machine can pose residual risks during maintenance. To eliminate these risks, all persons working on the machine must follow the general and machine-specific safety instructions.

#### Maintenance intervals

- Strictly adhere to the maintenance intervals.
- Check the safety equipment regularly to ensure it is in good condition and functioning properly.
- Check connections, cables and fasteners regularly to ensure they are in good condition.

#### Maintenance work

Maintenance work that goes beyond the scope described in this manual must only be performed by qualified technicians. We recommend that you work with one of the over 500 **HATZ service stations**.



#### Replacing parts

- When replacing parts, we recommend the use of **HATZ original spare parts** (see the chapter 2 *General information, page 6*).
- When disposing of parts that can no longer be used, do so in accordance with local environmental regulations or send them to a recycling center.







#### Measures following maintenance and troubleshooting

- Securely reconnect loose electrical connections; check that the electrical components and equipment are functioning properly.
- Check the entire machine for foreign bodies; remove any foreign bodies.

#### Safety instructions for maintenance work







 <b>DANGER</b>	
	<p><b>Danger of explosion from flammable cleaning agents.</b></p> <p>Cleaning with benzene is an explosion hazard. It is highly flammable, can become electrostatically charged and can generate an explosive gas-air mixture.</p> <ul style="list-style-type: none"><li>▪ Use halogen-free, cold cleaners with a high flashpoint for cleaning.</li></ul>



 <b>WARNING</b>	
 	<b>Danger of injury from compressed air and dust particles.</b> Eye injuries may occur when cleaning with compressed air. <ul style="list-style-type: none"><li>▪ Wear safety goggles.</li></ul>
 <b>CAUTION</b>	
	<b>Danger of injury if the maintenance instructions are not followed.</b> <ul style="list-style-type: none"><li>▪ Only perform maintenance while the engine is switched off.</li><li>▪ In engines with a starter: Disconnect the negative terminal of the battery. Protect the starting key against unauthorized access.</li></ul>
 <b>CAUTION</b>	
	<b>Danger of burns.</b> There is a danger of burns when working on a hot engine. <ul style="list-style-type: none"><li>▪ Let the engine cool before maintenance.</li></ul>

### 3.2.4 Electrical equipment

#### Safety notes

 <b>DANGER</b>	
	<p><b>Danger to life, danger of injury or danger of property damage due to incorrect use of batteries.</b></p> <ul style="list-style-type: none"> <li>▪ Do not place tools on the battery.</li> <li>▪ Before performing work on the electrical equipment, always disconnect the negative terminal of the battery.</li> <li>▪ Never swap the positive (+) and negative (–) battery terminals.</li> <li>▪ When installing the battery, first connect the <b>positive cable</b> and then the <b>negative cable</b>.</li> <li>▪ When removing the battery, first disconnect the <b>negative cable</b> and then the <b>positive cable</b>.</li> <li>▪ It is imperative that you prevent short circuits and mass contact of current-carrying cables.</li> <li>▪ If faults occur, check the cable connections for good contact.</li> </ul>
 <b>DANGER</b>	
	<p><b>Danger of explosion from flammable substances.</b></p> <p>There is a danger of explosion from flammable gases.</p> <ul style="list-style-type: none"> <li>▪ Keep batteries away from open flames and incandive sparks.</li> <li>▪ Do not smoke when working with batteries.</li> </ul>
 <b>CAUTION</b>	
	<p><b>Danger of chemical burns</b></p> <p>Chemical burns can occur when using batteries for the electrical operation.</p> <ul style="list-style-type: none"> <li>▪ Protect your eyes, skin and clothing from the corrosive battery acid.</li> <li>▪ Immediately rinse areas affected by splashed acid with clear water and consult a physician if necessary.</li> </ul>

**NOTICE**

- The necessary wiring diagrams are included with the machine if it is equipped with electrical equipment. Additional wiring diagrams can be requested when needed.
- We cannot be held liable for electrical equipment that is not designed according to HATZ wiring diagrams.

- Promptly replace faulty indicator lamps.
- Do not pull out the starting key during operation.
- Do not disconnect the battery while the machine is running. Resulting voltage peaks could destroy the electronic components.
- When performing a manual emergency start, leave the (possibly depleted) battery connected.
- When cleaning, do not spray the electrical equipment components with a water jet or high pressure cleaner.
- When performing welding work on the machine, disconnect the battery and place the ground clamp of the welding equipment as close as possible to the welding area. Disconnect the plug-in connection to the voltage regulator.
- The following additionally applies before starting emergency operation without the battery:
  - In models with an instrument box on the engine, disconnect the plug-in connection to the voltage regulator. Turn the starting key to pos. "0" and remove.
  - In models with an external instrument box, disconnect the plug-in connection to the instrument box.

### 3.3 Labels

#### Overview

The following labels are found on the machine:

- Engine type plate
- Warning labels and information signs on the engine

### Engine type plate

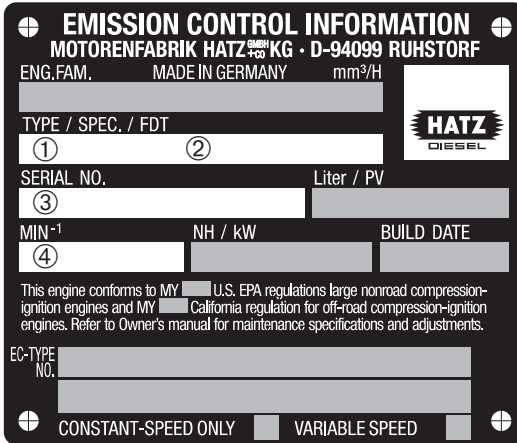

The engine type plate is located on the sound protection hood and contains the following engine information:

1	Engine type
2	Code (special models only)
3	Engine serial number (engraved on the crankcase)
4	Max. engine speed (rpm)

These data must always be specified for requests and spare part orders.

### Warning labels and information signs

Label	Meaning
	<p>Maintenance instructions (see the chapter 8.1 <i>General maintenance instructions</i>, page 47)</p>

Label	Meaning
	<p>Starting the engine with recoil start (see the chapter 7.4.1 <i>Starting the engine with recoil start (up to -6 °C)</i>, page 33)</p>
	<p><b>CAUTION</b>            Danger of injury from faulty starter rope.            A chafed starter rope can rip and cause injuries.</p> <ul style="list-style-type: none"> <li>Before using the starter rope, check for abrasion; replace the rope if necessary.</li> </ul>
	<p>Speed adjustment with connecting rod (additional equipment)</p>
	<p>Refuel with diesel fuel only. For the specification, see the chapter 4.2 <i>Fuel</i>, page 24            Do not use bio diesel.</p>

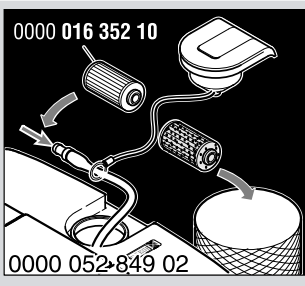
Label	Meaning
 <p>0000 016 352 10</p> <p>0000 052 849 02</p>	<p>Changing the fuel filter (see the chapter 8.2.11 <i>Changing the fuel filter</i>, page 68)</p>

## 4 Technical data

### 4.1 Engine

Type		1B20	1B27	1B30	1B40	1B50
Type		Air-cooled four stroke diesel engine				
Combustion system		Direct injection				
Number of cylinders		1	1	1	1	1
Bore/stroke	mm	69 / 65	74 / 65	80 / 69	88 / 76	93 / 76
Displacement	cm <sup>3</sup>	243	280	347	462	517
Tank capacity	Ltr.	3	3	5	5	5
Engine oil capacity						
Without oil sump	Approx. ltr.	0,9 <sup>1)</sup>	0,9 <sup>1)</sup>	1,1 <sup>1)</sup>	1,5 <sup>1)</sup>	1,5 <sup>1)</sup>
With oil sump	Approx. ltr.	2,6 <sup>1)</sup>	-	2,8 <sup>1)</sup>	3,2 <sup>1)</sup>	-
Difference between the "max." and "min." mark						
Without oil sump	Approx. ltr.	0,5 <sup>1)</sup>	0,5 <sup>1)</sup>	0,5 <sup>1)</sup>	0,8 <sup>1)</sup>	0,8 <sup>1)</sup>
With oil sump	Approx. ltr.	1,6 <sup>1)</sup>	-	1,8 <sup>1)</sup>	2,2 <sup>1)</sup>	-
Engine oil consumption (after running-in period)	Max.	1% of fuel consumption, pertaining to full load				
Engine oil pressure at oil temperature of 100 °C	Approx.	2.5 bar at 3000 rpm				
Sense of rotation on power take-off side		Left				
Tappet clearance at 10 - 30 °C						
Inlet/Outlet	mm	0,20 <sup>2)</sup>	0,10 <sup>2)</sup>	0,10 <sup>2)</sup>	0,10 <sup>2)</sup>	0,10 <sup>2)</sup>
Max. perm. inclination during continuous operation in direction		Flywheel low 25° <sup>3)</sup> Other directions 35° <sup>3)</sup>				
Weight (incl. fuel tank, air filter, silencer, recoil start and electric start)	Approx. kg	33	34	40	55	56
Battery capacity	Min / max	12 V – 36/60 Ah/24 V – 24/44 Ah				

<sup>1)</sup> These values are approximations only. The correct level is indicated by the max. mark on the dipstick (see the chapter 7.8 *Checking the oil level and adding oil if necessary, page 44*).

<sup>2)</sup> If equipped with an **automatic valve lash adjustment**, the tappet clearance does not need to be checked (see the chapter 8.2.2 *Maintenance plan*, page 49).

<sup>3)</sup> Exceeding these limit values causes engine damage.

### Screw tightening torque

Designation	Nm
Oil drain screw	50

## 4.2 Fuel

### Fuel type

All types of diesel fuel that meet the minimum requirements of the following specifications are suitable:

- **EN 590** or
- **BS 2869 A1 / A2** or
- **ASTM D 975- 1D / 2D**

CAUTION	
	<p><b>Danger of engine damage from low quality fuel.</b></p> <p>The use of fuel that does not meet the specifications can lead to engine damage.</p> <ul style="list-style-type: none"> <li>▪ The use of fuel that does not meet specifications requires approval by Motorenfabrik HATZ (main plant).</li> </ul>

### Winter fuel

When outside temperatures drop below 0 °C, use winter fuel or mix in petroleum in advance:

Lowest ambient temperature at start [°C]	Percentage of petroleum [%] for	
	Summer fuel	Winter fuel
0 to -10	20	-
-10 to -15	30	-
-15 to -20	50	20
-20 to -30	-	50

## 4.3 Engine oil

### Engine oil

All oil brands that meet at least one of the following specifications are suitable:

- **ACEA – B2 / E2** or better
- **API – CD / CE / CF / CF-4 / CG-4** or better



If engine oils of a low quality standard are used, the oil change interval must be reduced to 150 operating hours.

### Oil viscosity

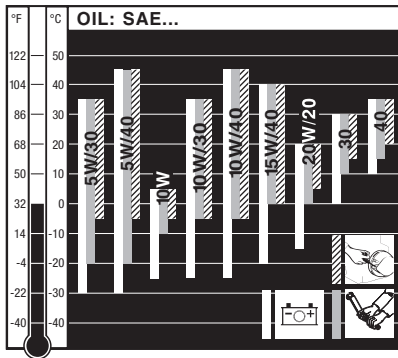

Choose the recommended viscosity based on the type of start (recoil, crank-handle or electric) and on the engine temperature at which the engine will be operated.

### CAUTION

#### Engine damage from unsuitable engine oil.

Using engine oil that does not meet the above specifications considerably shortens the engine service life.

# 5 Engine design

## Overview

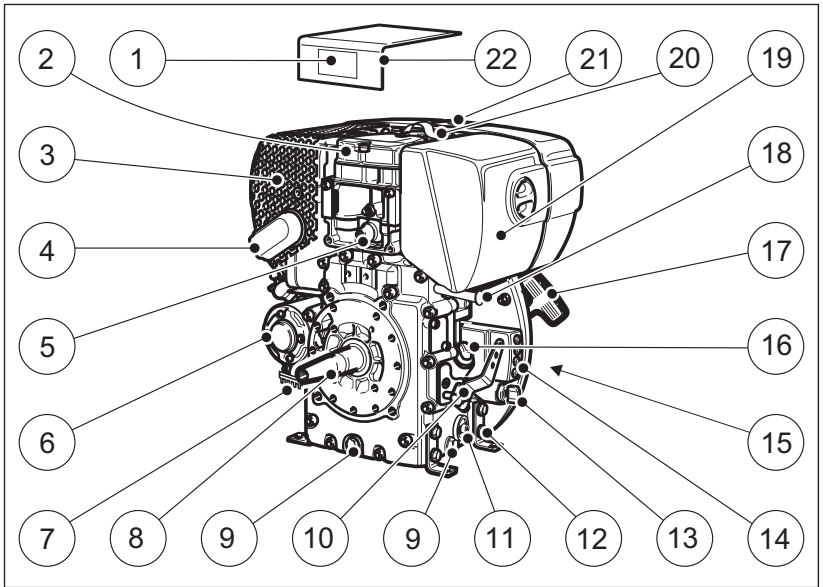

Pos.	Designation
1	Type plate
2	Cylinder head cover
3	Silencer with contact protection
4	Exhaust manifold with exhaust screen
5	Oil pressure switch <sup>1)</sup>
6	Starter <sup>1)</sup>
7	Voltage regulator <sup>1)</sup>
8	Crankshaft – power take-off (pto)
9	Oil drain screw
10	Speed control lever
11	Screw cap for oil filter
12	Engine fixation
13	Starting key <sup>1)</sup>
14	Indicators <sup>1)</sup>

Pos.	Designation
15	Intake opening for cooling and combustion air
16	Oil filling opening and dipstick
17	Recoil start
18	Stop pin (option)
19	Dry air filter
20	Lifting eye
21	Fuel cap
22	Sound protection hood





<sup>1)</sup> Only in model with electrical equipment.

The engine can optionally be supplied with an **external** instrument box.

## 6 Transport, assembly and commissioning

### 6.1 Transport

#### Safety notes

 <b>CAUTION</b>	
	<p><b>Danger of injury from overloading the body.</b> Lifting the machine to transport it or to move it to another location can lead to injuries (of the back, for example).</p> <ul style="list-style-type: none"> <li>▪ Only lift the machine with a hoist.</li> </ul>
 <b>CAUTION</b>	
	<p><b>Only use lifting lugs for transporting the engine.</b> Do not use for lifting the entire equipment.</p>
<b>NOTICE</b>	
	<p><b>Danger of environmental damage from leaking fluid.</b> If the machine is tilted, engine oil and diesel fuel can run out.</p> <ul style="list-style-type: none"> <li>▪ Only transport the machine in an upright position.</li> </ul>

#### Transport conditions

- Only lift the engine by the standard fitted lifting lugs.
- When transporting the machine, follow the safety instructions.
- When transporting, follow the applicable safety and accident prevention regulations of the trade associations.
- After delivery, check the machine for completeness and transport damage.
- Only transport the machine when it is switched off and has cooled down.
- If you have questions on transporting the machine, please contact your nearest **HATZ service station**. For contact data, see the chapter 1 "Notices", page 5 or [www.hatz-diesel.com](http://www.hatz-diesel.com).

### 6.2 Assembly instructions

#### Assembly notes

HATZ diesel engines are efficient, robust and long-lived. Therefore, they are usually installed in machines that are used for commercial purposes.

The machine manufacturer must follow the applicable regulations regarding machine safety – the engine is a part of a machine.

Depending on the use and installation of the engine, it may be necessary for the machine manufacturer and machine user to install safety equipment to prevent inappropriate use. Note the following:

- Parts of the exhaust gas system and the engine surface become hot during operation and may not be touched until they cool down after the engine is switched off.
- Incorrect cable connections and incorrect operation of the electrical equipment can lead to sparking and must be avoided.
- After the engine is installed in the machine, rotating parts must be protected against contact.

HATZ safety equipment is available for the belt drive of the cooling fan and alternator.

- Comply with all notice and warning labels on the engine and keep them in a legible condition. If a label should become detached or be difficult to read, it must be replaced promptly. For this purpose, contact your nearest **HATZ service station**.
- Any improper modification of the engine results in a loss of liability coverage for resulting damage.



Only regular maintenance, as specified in this Operator's Manual, will maintain the operating readiness of the engine.

**The** assembly instructions contain important information on how to safely assemble the engine. They are available from any **Hatz service station**.

If you have any questions, please contact your nearest **HATZ service station** before commissioning the engine.

### 6.3 Preparations for commissioning

- Check the delivered parts for completeness, damage and other noticeable issues.
- Ensure that the setup location is adequately ventilated.

 <b>DANGER</b>	
	<p><b>Danger to life from inhaling exhaust gases.</b></p> <p>Toxic engine exhaust gases can lead to loss of consciousness and even death in closed-off and poorly ventilated rooms.</p> <ul style="list-style-type: none"> <li>▪ Never operate the machine in closed-off or poorly ventilated rooms.</li> <li>▪ Do not breathe in the exhaust gases.</li> </ul>

## 7 Operation and use

### 7.1 Safety notes

#### NOTICE



##### Comply with the safety chapter!

Follow the basic safety instructions in the chapter 3 *Safety*, page 7.



#### DANGER



##### Danger to life due to damage and defects on the machine.

- Do not take the machine into service if damage has been localized and identified.
- Replace faulty components.



#### WARNING



##### Danger of injury from the failure to follow the operating instructions and from performing unauthorized tasks on the machine.

- Define the responsibilities of the personnel taking the machine into service.
- Replace faulty machine parts immediately.
- Check the installation conditions when the machine is first taken into service and after the machine has been inactive for a lengthy period.

#### CAUTION

##### Danger of engine damage from low load operation.

Operating the engine at no load or at very low load for an extended period can impair the running characteristics of the engine.

- Ensure that the engine load is at least 15 %.
- Before switching off the engine following low load operation, briefly operate it at a considerably higher load.

**CAUTION**

**Exceeding of the permissible forces at the speed control lever and stop pin can cause damage to the stops and inside regulator parts.**

Please note the following figure.

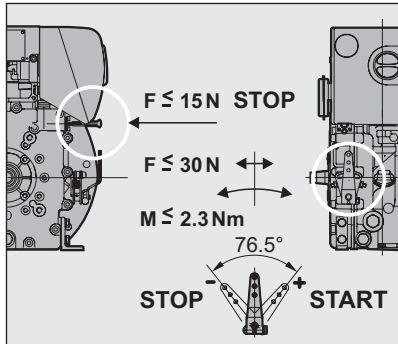
**Max. permissible forces on the speed control lever****7.2 Performing tests****Before starting**

Before starting the engine, several tests need to be performed to ensure the machine is working properly.

**Procedure**

Step	Test
1	The machine is standing securely and on a level surface.
2	The installation location is adequately ventilated.
3	There is a sufficient amount of fuel in the fuel tank (see the chapter 4.2 <i>Fuel</i> , page 24).
4	There is a sufficient amount of engine oil in the engine housing (see the chapter 4.3 <i>Engine oil</i> , page 24).
5	The starter rope of the recoil start does not exhibit abrasion (hand start).
6	The oil bath filter (option) is filled with engine oil (see the chapter 7.8.2 <i>Oil level in the oil bath filter (option)</i> , page 46).

### 7.3 Setting the speed control

**Safety note**

<b>CAUTION</b>	
	<p><b>Damage to the diesel engine due to inadequate lubrication.</b></p> <ul style="list-style-type: none"> <li>After the engine has been out of use for an extended period (approx. 6 months or longer) or when the engine is first taken into service, operate the engine at a low set speed and without a load for approx. 20 seconds after starting. This ensures good lubrication of all bearing points before the speed and load are increased.</li> </ul>

**Overview**

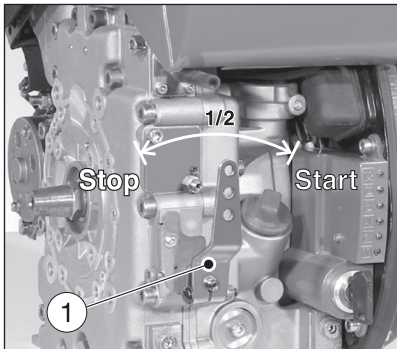

**Procedure**

Step	Activity
1	First move the speed control lever (1) to the "Stop" position.
2	Depending on the possibility or requirement, place the speed control lever in either the "1/2" or "Start" position.  <b>Note:</b> A lower speed setting will cause less exhaust smoke when starting.

### 7.4 Starting the engine

**Starting options**

The standard equipment of the engine is a hand start mechanism. A starter can be installed as an option.

If possible, separate the engine from the machine being driven by uncoupling it. Always switch the machine into idle mode.



## Safety notes

### DANGER



#### **Danger to life from inhaling exhaust gases.**

Toxic engine exhaust gases can lead to loss of consciousness and even death in closed-off and poorly ventilated rooms.

- Never operate the machine in closed-off or poorly ventilated rooms.
- Do not breathe in the exhaust gases.

### WARNING



#### **Danger of injury from faulty starter rope.**

A chafed starter rope can rip and cause injuries.

- Before using the starter rope, check for abrasion; replace the rope if necessary.

### CAUTION



#### **Danger of injury and danger of engine damage from the use of starting fluid.**

- Danger of injury during hand starting because the use of starting fluid can result in uncontrolled ignitions.
- Engine damage from uncontrolled ignitions.
- Never use starting fluid.

## 7.4.1 Starting the engine with recoil start (up to -6 °C)

### Overview

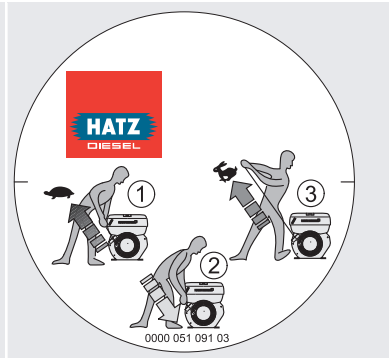
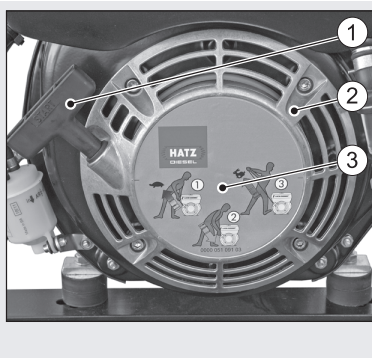

Pos.	Designation
1	Grip
2	Recoil start cover
3	Diagram of starting procedure

**Procedure**



Step	Activity
1	Check the speed control (see the chapter 7.3 <i>Setting the speed control</i> , page 32).
2	Slowly pull out the grip with the rope until you encounter a slight resistance.
3	Let the rope run back in to be able to use the entire rope length for the starting procedure.
4	Hold the grip with both hands.
5	Pull the starting rope evenly and with increasing speed (do not tear at it jerkily) until the engine starts.

**NOTICE**



**When the exhaust emits white smoke after several failed start procedures:**

- Move the speed controller lever to the "Stop" position.
- Pull the starting rope all the way out five times.
- Readjust the speed control (see the chapter 7.3 *Setting the speed control*, page 32).
- Repeat the start procedure.

## 7.4.2 Starting the engine with an electric starter

### Overview

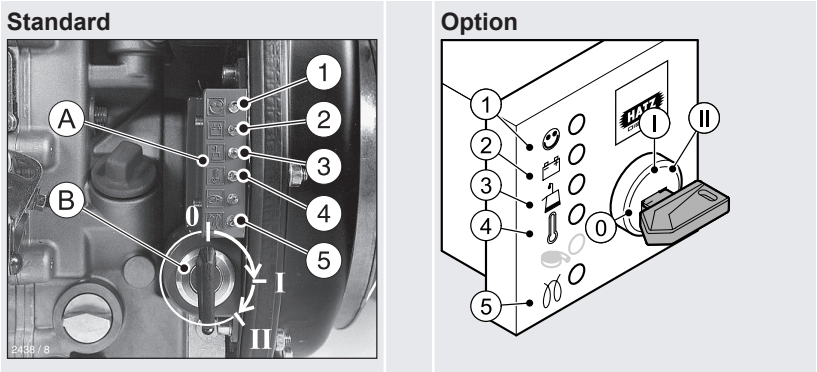

Pos.	Designation
A	Indicators
	1 – Operating display
	2 – Charge control
	3 – Oil pressure display
	4 – Engine temperature display (option)
5 – Pre glow display (option)	
B	Ignition lock
	0 – Off
	I – Operation
	II – Starting

### Procedure

#### NOTICE



- Start for max. 30 seconds. If the engine still is not running after that, turn the starting key back to position "0" and eliminate the cause (see the chapter 9 *Faults*, page 77).
- Turn the starting key to position "0" every time you want to start the engine.
- The anti-repeat device in the ignition lock makes it impossible for the starter to engage while the engine is running and become damaged.

Step	Activity
1	Check the speed control (see the chapter ).
2	<p>Insert the starting key all the way and turn to position "I". Depending on the model, the following indicators light up:</p> <ul style="list-style-type: none"> <li>▪ Charge control (2)</li> <li>▪ Oil pressure display (3)</li> <li>▪ Pre glow display (5)</li> </ul> <p><b>NOTES:</b></p> <ul style="list-style-type: none"> <li>▪ If the engine temperature display (4) lights up, the cylinder head temperature is impermissibly high. Do not start the engine; eliminate the cause.</li> <li>▪ When the optional pre glow display (5) goes out, continue with step 3.</li> </ul>
3	Turn the starting key to position "II".
4	<p>As soon as the engine is running, release the starting key.</p> <ul style="list-style-type: none"> <li>▪ The starting key springs back to position "I" and remains in this position during operation.</li> <li>▪ The charge control (2) and oil pressure display (3) go out.</li> <li>▪ The operating display (1) lights up.</li> </ul>

### NOTICE



- In case of irregularities, switch off the engine immediately.
- Identify the fault and eliminate it.
- For details of troubleshooting, see the chapter *9 Faults*, page 77.

### Electrical automatic shutoff (additional equipment)

The distinguishing feature of the electrical automatic shutoff is brief flashing of all indicators after turning the starting key to position "I".

**NOTICE**

- If the engine stops again immediately after starting, or stops independently during operation, this is an indication that a monitoring element of the automatic shutoff has been activated.
- Remedy the malfunction before further starting attempts (see the chapter *9.1 Troubleshooting, page 77*).
- Despite the automatic shutoff, check the oil level every 8-15 operating hours (see the chapter *7.8 Checking the oil level and adding oil if necessary, page 44*).
- If the fuel shutoff valve (additional equipment) is blocked due to an electrical fault of the fuel supply and the engine therefore does not start, an emergency start can be carried out (see the chapter *9.2 Emergency start, page 83*).

## 7.5 Switching off the engine

### Procedures

The engine can be switched off in different ways depending on how it is equipped:

- Speed control lever (mechanical)
- Stop pin (mechanical)
- Starting key (electrical)

### 7.5.1 Switching off the engine (mechanical)

**NOTICE**

Engines with a blocked lower idle speed cannot be switched off with the speed control lever. In this case, the engine is switched off with the stop pin or starting key, depending on how the engine is equipped.

**Overview**

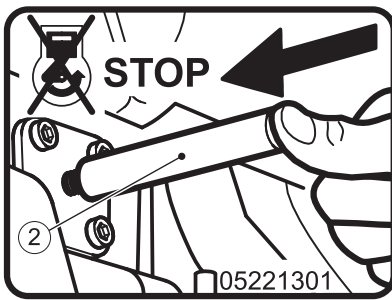
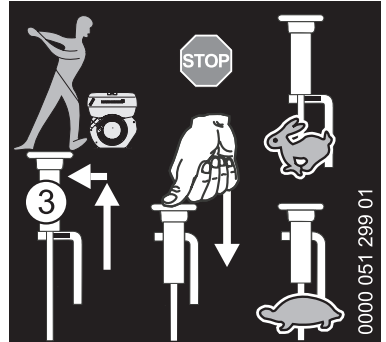
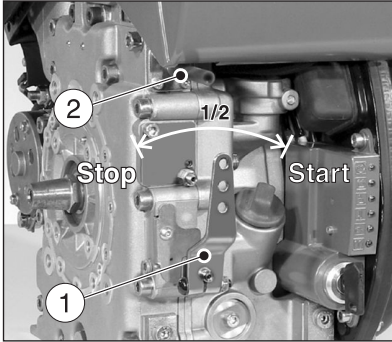



Pos.	Designation
1	Speed control lever
2	Stop pin (additional equipment)
3	Connecting rod (additional equipment)

**Procedure**

Step	Activity
<b>Speed control lever</b>	
1	Push the speed control lever (1) all the way to the "STOP" position. The engine switches off.
<b>Stop pin</b>	
1	Press and hold the stop pin (2) until the engine switches off.
2	Release the stop pin and ensure that it returns to its original position.
<b>Speed adjustment with connecting rod (additional equipment)</b>	
1	Move the speed adjustment with the connecting rod (3) to the "STOP" position and press it until the engine switches off.

## 7.5.2 Switching off the engine (electrical)

### Safety notes

 <b>CAUTION</b>	
	<p><b>Danger of injury due to operation by unauthorized persons.</b></p> <p>There is a danger of injury if unauthorized persons handle the machine.</p> <ul style="list-style-type: none"> <li>Remove the starting key and protect it against unauthorized access during breaks in operation or after finishing work for the day.</li> </ul>

### Overview

#### Standard

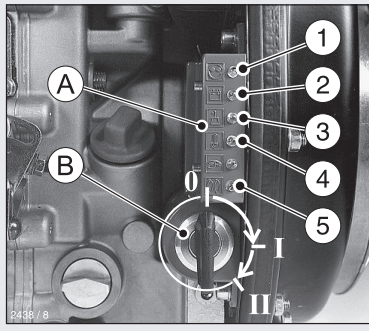

#### Option

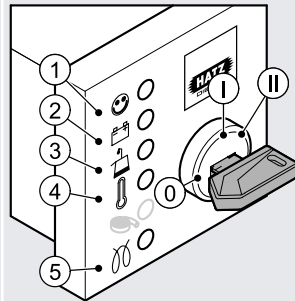

### Procedure

#### NOTICE



#### Danger of full battery discharge.

- When the machine is switched off, always turn the starting key to position "0" or else the battery may become fully discharged.

Step	Activity
1	Turn the starting key to position "0". <ul style="list-style-type: none"> <li>The engine switches off.</li> <li>All indicator lamps go out.</li> </ul>
2	Remove the starting key.

### Automatic electrical switch-off with fault storage

This is identified by brief flashing of all indicators after the starting key is turned to position "I".



<b>NOTICE</b>	
	<p>If the engine stops again immediately after starting, or stops independently during operation, this is an indication that a monitoring element of the automatic shutoff has been activated.</p>

### Procedure

Step	Activity
1	<p>Check the indicators (2-4).</p> <p>After the engine comes to a standstill, the fault will continue to be displayed by the indicator for approx. another 2 minutes.</p>
2	<p>Then the electrical equipment switches off automatically.</p>
3	<p>Set the starting key to position "0".</p>
4	<p>Turn the starting key back to position "I".</p> <p>The fault display lights up again.</p> <p>Remedy the fault before further starting attempts (see the chapter 9 <i>Faults</i>, page 77).</p> <p>The indicator goes out at the next start.</p>

## 7.6 Refueling

### Safety notes

 <b>DANGER</b>	
 	<p><b>Fire hazard from fuel.</b></p> <p>Leaked or spilled fuel can ignite on hot engine parts and cause serious burn injuries.</p> <ul style="list-style-type: none"> <li>▪ Only refuel while the engine is switched off.</li> <li>▪ Never refuel in the vicinity of open flames or sparks that can cause ignition.</li> <li>▪ Do not smoke.</li> <li>▪ Do not spill fuel.</li> </ul>



**CAUTION****Danger of environmental damage from spilled fuel.**

Do not overfill the fuel tank and do not spill fuel.

- Collect emerging fuel and dispose of it in an environmentally compatible manner.

**CAUTION****Engine damage from using low quality fuel.**

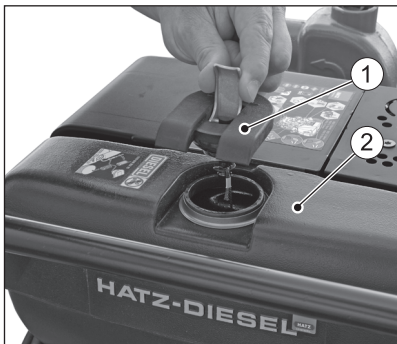

The use of fuel that does not meet the specifications can lead to engine damage.

- Only use the fuel specified in the chapter 4.2 *Fuel*, page 24.
- The use of fuel that does not meet specifications requires approval by Motorenfabrik HATZ (main plant).

**Overview**

Pos.	Designation
1	Fuel cap
2	Fuel tank

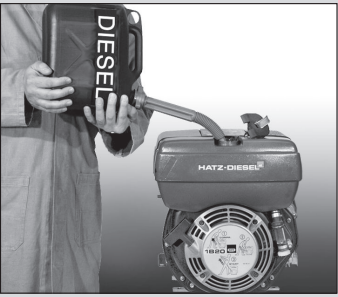
**Procedure**

Step	Activity	Figure
1	Open the fuel cap.	
2	Fill the fuel tank with diesel fuel.	
3	Close the fuel cap.	

**NOTICE**



- Before starting for the first time or if the fuel system is empty, fill the fuel tank fully with diesel fuel. This causes the fuel system to be bled automatically.
- Automatic bleeding is completed after a waiting period of 1-2 minutes. The engine is ready to start.

## 7.7 Checking the water separator

### Safety notes



#### CAUTION



#### Danger of environmental damage from spilled fuel.

When water is drained from the water separator, a small amount of fuel is drained as well.

- Catch the emerging water-fuel mixture and dispose of it in an environmentally compatible manner.

#### NOTICE



The interval for checking the water separator depends entirely on the proportion of water in the fuel and on the care exercised during refueling; the water separator should be checked at least once a week.

### Overview

Water in the fuel tank collects at the lowest point of the fuel tank in the water separator.

#### Standard

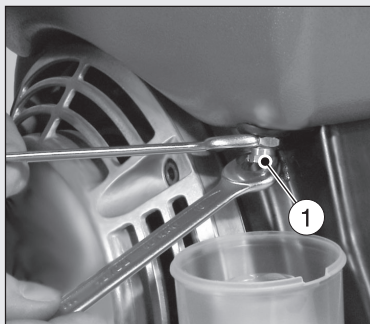

#### Model with window

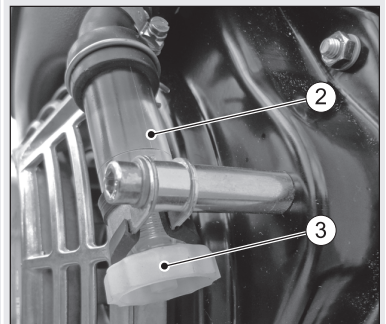



Pos.	Designation
1	Drain screw, hex (standard)
2	Window (additional machine)
3	Drain screw (manually operated)

## Procedure

Step	Activity
1	Model with window: Check the window (2) for water content. Collected water can be clearly identified by the noticeable separating line between the water and the diesel fuel above it.
2	Place a suitable container under the drain screw (1) or (3). <i>NOTE:</i> In inaccessible locations, an extension hose can be mounted on the drain screw (3).
3	Open the drain screw (1) or (3) and drain the water into the container.
4	When fuel emerges, close the drain screw.
5	Dispose of the water-fuel mixture in an environmentally compatible manner.

## 7.8 Checking the oil level and adding oil if necessary

### Safety notes

 <b>CAUTION</b>	
  	<p><b>Danger of burns.</b></p> <p>There is a danger of burns when working on a hot engine.</p> <ul style="list-style-type: none"> <li>▪ Wear safety gloves.</li> </ul>
<b>CAUTION</b>	
	<p><b>Danger of later engine damage.</b></p> <ul style="list-style-type: none"> <li>▪ Operating the engine with an oil level below the min. mark or above the max. mark can lead to engine damage.</li> <li>▪ When checking the oil level, the machine must be horizontal and the engine must be switched off.</li> </ul>

## 7.8.1 Engine oil level

### Overview

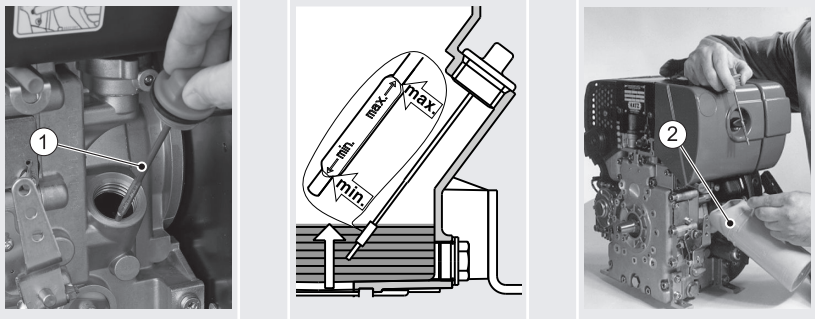

Pos.	Designation
1	Dipstick
2	Oil refilling container

### Procedure

Step	Activity
1	Switch off the engine and wait several minutes for the engine oil to collect in the crank housing. The machine must be horizontal.
2	Remove contamination on the engine in the area of the dipstick.
3	Unscrew the dipstick and clean it.
4	Reinsert the dipstick and screw it tight.
5	Unscrew the dipstick and check the oil level.
6	If the oil level is close to the min. mark, add engine oil to the max. mark.
7	Reinsert the dipstick and screw it tight.

## 7.8.2 Oil level in the oil bath filter (option)

### Overview

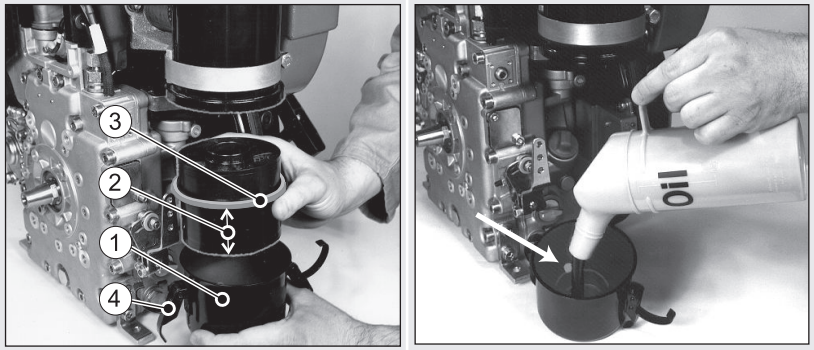

Pos.	Designation
1	Oil container
2	Filter insert
3	Gasket
4	Lock



### Procedure

Step	Activity
1	Remove the oil container (1) and fill it to the mark with engine oil.
2	Insert the long end of the filter insert (2) into the oil container.
3	Mount the oil container, ensuring that the gasket (3) is properly positioned and the locks (4) are correctly fastened.

## 8 Maintenance

### 8.1 General maintenance instructions

#### Safety notes

 <b>WARNING</b>	
	<p><b>Danger of injury from the failure to follow the operating instructions and from performing unauthorized tasks on the machine.</b></p> <ul style="list-style-type: none"> <li>▪ Follow all instructions.</li> <li>▪ Do not perform activities that are not authorized. Contact properly trained personnel if necessary.</li> </ul>

<b>NOTICE</b>	
	<p><b>Comply with the safety chapter!</b></p> <p>Follow the basic safety instructions in the chapter 3 <i>Safety</i>, page 7.</p>

- Maintenance tasks may only be performed by trained personnel.
- Accident prevention measures must be in accordance with the local accident prevention regulations.
- Perform setting and maintenance work at the specified intervals.
- Replace faulty machine parts as soon as possible.
- Always use personal protective equipment.
- Only use fully functional tools.
- Problems may occur if unsuitable spare parts are installed. We cannot accept responsibility for damage and secondary damage that result from this. We therefore recommend the use of **Hatz original spare parts**.
- Closely adhere to the maintenance conditions prescribed in this Operator's Manual.
- Only make changes on the machine in agreement with the manufacturer.
- Only perform maintenance while the engine is switched off.
- Adhere to legal regulations when handling and disposing of used oil, filters and cleaning agents.
- Protect the starting key against unauthorized access.
- For engines with a electric starter: disconnect the negative battery terminal.
- After completing maintenance work, check that all tools, bolts, aids and other objects are removed from the machine and that all safety equipment has been replaced.

- Before starting, ensure that no persons are located in the danger zone of the engine or machine.



### Performance of maintenance work

The entire machine is designed to be maintenance friendly. Parts that require maintenance are easily accessible.

- Perform maintenance work faithfully at the specified intervals to prevent premature wear of the machine.
- Follow the notice and warning labels on the machine.
- Always retighten screw connections loosened during maintenance work.
- After the necessary maintenance and repair work is completed, perform a function test (test run).
- For maintenance work that is not listed and described in the maintenance documentation, please contact your nearest **HATZ service station**.

## 8.2 Maintenance work

### Safety note



 <b>CAUTION</b>	
	<p><b>Danger of injury if the maintenance instructions are not followed.</b></p> <ul style="list-style-type: none"> <li>▪ Only perform maintenance while the engine is switched off.</li> <li>▪ Protect the starting key against unauthorized access.</li> <li>▪ For engines with a starter: disconnect the negative battery terminal.</li> <li>▪ After the maintenance work is completed, ensure that all tools have been removed from the machine.</li> </ul>



### 8.2.1 Maintenance notice label

<b>NOTICE</b>	
	<p>Depending on whether or not the engine is equipped with an automatic valve lash adjustment, the appropriate maintenance plan shown here is supplied with the engine.</p> <p>It should be mounted on the engine in a clearly visible location. The maintenance intervals specified on the maintenance plan must be adhered to (see the chapter <i>8.2.2 Maintenance plan</i>, page 49).</p>





Symbol	Maintenance interval	Maintenance activity/check	Chapter
	Every 8-15 operating hours or every day before starting	Check the oil level.	<i>7.8 Checking the oil level and adding oil if necessary, page 44</i>
		Check the engine oil level in the bottom section of the oil bath filter and examine the oil for contamination. Change the oil if it is sludgy.	<i>8.2.7 Maintaining the oil bath filter, page 60</i>
		In models with a cyclone pre-cleaner: remove the dust trap.	
		Check the intake area of the combustion and cooling air.	<i>8.2.3 Checking the intake area, page 51</i>
		Check the air filter maintenance indicator.	<i>8.2.12 Maintaining the dry air filter, page 73</i>
		Check the water separator.	<i>7.7 Checking the water separator, page 43</i>
	Every 250 operating hours	Maintain the oil bath filter.	<i>8.2.7 Maintaining the oil bath filter, page 60</i>
		Change the engine oil.	<i>8.2.4 Change the engine oil, page 53</i>
		Check and adjust the tappet clearance (not in models with an automatic valve lash adjustment).	<i>8.2.6 Check and set the tappet clearance, page 56</i>
		Clean the cooling air area.	<i>8.2.8 Clean the cooling air area, page 61</i>
		Check the screw connections.	<i>8.2.9 Check the screw connections, page 64</i>
		Clean the exhaust screen.	<i>8.2.10 Clean the exhaust screen, page 64</i>

Symbol	Maintenance interval	Maintenance activity/check	Chapter
	Every 500 operating hours	Change the fuel filter.	8.2.11 <i>Changing the fuel filter, page 68</i>
		Maintain the dry air filter.	8.2.12 <i>Maintaining the dry air filter, page 73</i>
	Every 1000 operating hours	Clean the oil filter.	8.2.5 <i>Clean the oil filter, page 54</i>





In new and generally overhauled engines, after 25 operating hours:

- Change the engine oil
- Check the tappet clearance and adjust if necessary
- Check the screw connections (do not retighten the screws for attaching the cylinder head)



In case of a low number of operating hours, change the engine oil no later than every 12 months, regardless of the actual number of operating hours.

### 8.2.3 Checking the intake area

#### Safety notes

 <b>CAUTION</b>	
  	<p><b>Danger of burns.</b></p> <p>There is a danger of burns when working on a hot engine.</p> <ul style="list-style-type: none"> <li>▪ Let the engine cool.</li> <li>▪ Wear safety gloves.</li> </ul>
<b>NOTICE</b>	
	<p>In case of heavy contamination, shorten the maintenance intervals accordingly (see the chapter <i>8.2.2 Maintenance plan, page 49</i>).</p>

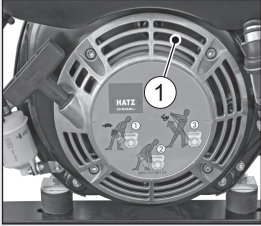
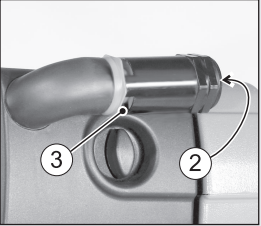
## Overview



Standard	Model with cyclone precleaner	Model with oil bath filter
		
Pos.	Designation	
1	Air intake opening	
2	Intake area of cyclone precleaner	
3	Dust outlet opening	
4	Intake area of oil bath filter	

## Procedure

Step	Activity
1	Check the air intake opening (1) for coarse contamination such as leaves, heavy dust deposits, etc., and clean if necessary.
2	In models with a <b>cyclone precleaner</b> , also check and if necessary clean the intake area (2) in addition to step 1. Check that the dust outlet opening (3) is clear and clean it if necessary.
3	In models with an <b>oil bath filter</b> , also check and if necessary clean the intake area (4) in addition to step 1.

## 8.2.4 Change the engine oil

### Safety notes

<b>⚠ CAUTION</b>	
 	<p><b>Danger of burns.</b></p> <p>When working on the engine there is a danger of burns from hot oil.</p> <ul style="list-style-type: none"> <li>▪ Wear personal protective equipment (gloves).</li> <li>▪ Collect the used oil and dispose of it according to local environmental regulations.</li> </ul>
<b>NOTICE</b>	
	<ul style="list-style-type: none"> <li>▪ The engine must be level.</li> <li>▪ The engine must be switched off.</li> <li>▪ Only drain engine oil while it is warm.</li> <li>▪ The engine oil should be changed when the oil filter is cleaned (see the chapter <i>8.2.5 Clean the oil filter</i>, page 54), since oil will run out when the filter is pulled out.</li> </ul>

### Overview

**Without oil sump**

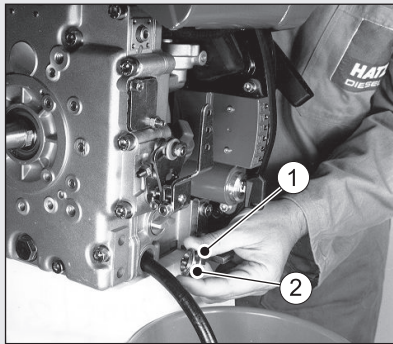

**With oil sump**

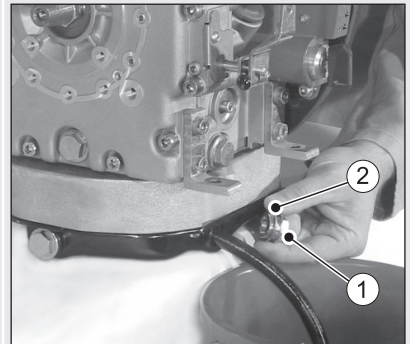







Pos.	Designation
1	Oil drain screw
2	Gasket

**Procedure**

Step	Activity
1	Unscrew the oil drain screw (1) and drain the oil entirely.
2	If necessary (every 1000 operating hours), clean the oil filter as per chapter 8.2.5 <i>Clean the oil filter, page 54</i> .
3	Screw in the cleaned oil drain screw (1) with the new gasket (2) and tighten. Tightening torque: 50 Nm.
4	Add engine oil (see the chapter 4.3 <i>Engine oil, page 24</i> ).

**8.2.5 Clean the oil filter****Safety notes**

 <b>CAUTION</b>	
	<p><b>Danger of burns.</b></p> <p>There is a danger of burns when working on a hot engine.</p> <ul style="list-style-type: none"> <li>Let the engine cool before maintenance.</li> </ul>
 <b>CAUTION</b>	
  	<p><b>Danger of injury.</b></p> <p>When working with compressed air, foreign bodies may fly into your eyes.</p> <ul style="list-style-type: none"> <li>Wear safety goggles.</li> <li>Never direct the compressed air jet toward people or toward yourself.</li> </ul>
<b>NOTICE</b>	
	<ul style="list-style-type: none"> <li>Capture emerging oil in a suitable container.</li> <li>Dispose of the oil according to legal regulations.</li> </ul>

**NOTICE**

- The oil filter should be cleaned when the engine oil is changed (see the chapter 8.2.4 *Change the engine oil*, page 53) since oil will run out when the filter is pulled out.
- The machine must be level when cleaning the oil filter.

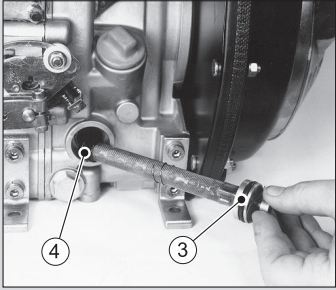
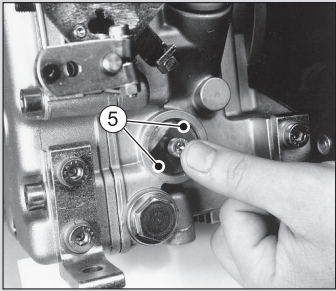

**Procedure**

Step	Activity	Figure
1	Loosen the screw (1) by approx. five turns.	
2	Pull the oil filter (2) out of the housing.	
3	Blow out the oil filter with compressed air from the inside to the outside.	

Step	Activity	Figure
4	Check the gasket (3) for damage and renew if necessary.	
5	Lightly oil the gaskets (3+4) before mounting.	
6	Insert the oil filter and press it all the way in.	
7	Before tightening the screw, ensure that the tension springs (5) rest against the oil filter at both ends. Tighten the screw.	
8	Check the oil level and add oil to the max. mark if necessary (see the chapter 4.3 <i>Engine oil</i> , page 24).	

## 8.2.6 Check and set the tappet clearance

### Safety notes

 <b>CAUTION</b>	
	<p><b>Danger of burns.</b></p> <p>There is a danger of burns when working on a hot engine. Only perform the settings while the engine is cold (10-30 °C).</p> <ul style="list-style-type: none"> <li>▪ Let the engine cool.</li> </ul>
<b>NOTICE</b>	
	<p>This chapter only applies to engines without an automatic valve lash adjustment.</p> <p>This can be identified on the supplied maintenance plan (see the chapter 8.2.2 <i>Maintenance plan</i>, page 49).</p>



## Preparations

The preparations are performed in different ways depending on how the engine is equipped:

- Preparations on engine model with dry air filter
- Preparations on engine model with oil bath filter
- Preparations on engine model with rammer operation (1B20 R)

### Preparation - Engine model with dry air filter

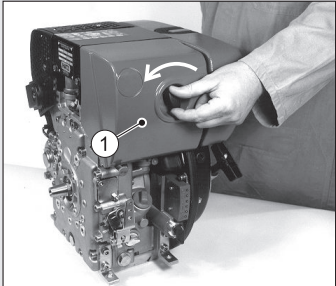
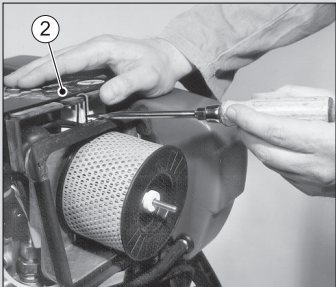
Step	Activity	Figure
1	Unscrew the air filter cap (1).	
2	Remove the sound protection hood (2).	

### Preparation - Engine model with oil bath filter

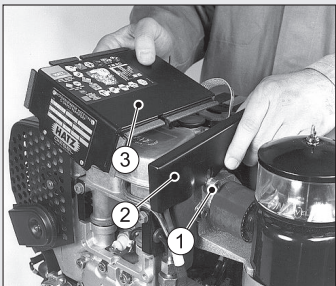
Step	Activity	Figure
1	Release the screw (1).	
2	Take off the cover plate (2) with the sound protection hood (3).	

**Preparations - Engine model with rammer operation (1B20 R)**

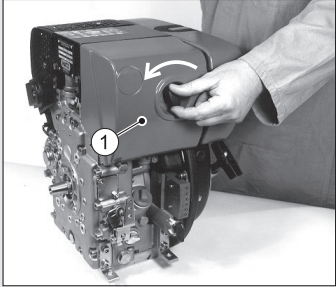
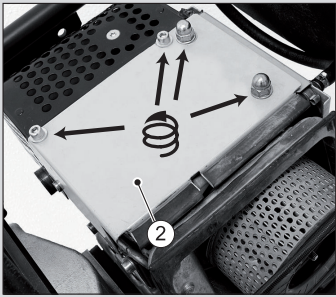
Step	Activity	Figure
1	Unscrew the air filter cap (1).	
2	Remove the screws and nuts. Remove the sound protection hood (2).	

**Procedure****NOTICE**

The steps described here can only be performed after the appropriate preparations have been completed.

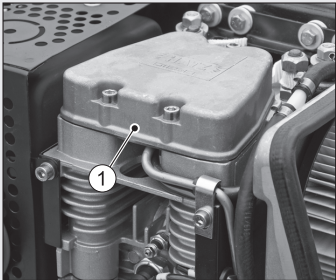
Step	Activity	Figure
1	Remove dirt in the area of the cylinder head cover (1).	

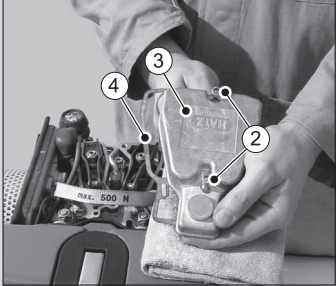
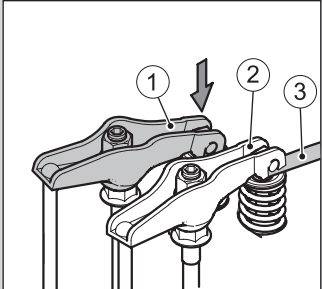
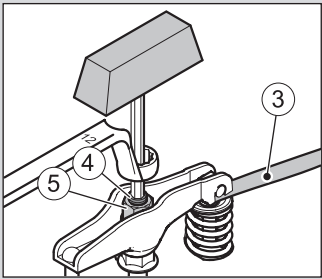
Step	Activity	Figure
2	Remove the screws (2). (2 screws in 1B20, 1B27 and 1B30, 3 screws in 1B40 and 1B50).	
3	Take off the cover (3) with the gasket (4).	
4	Turn the engine in the sense of rotation until the rocker arm (1) has fully opened the outlet valve. Then check the tappet clearance at the rocker arm (2) with a feeler gauge (3). For the setting, see the chapter 4.1 <i>Engine</i> , page 23.	
5	Turn the engine in the sense of rotation until the rocker arm (2) has fully opened the intake valve. Now check the tappet clearance at the rocker arm (1).	
6	If the tappet clearance needs to be corrected: Release the screw (4) and turn the hex nut (5) so the feeler gauge (3) can be pulled through with a barely perceptible resistance after the screw (4) is tightened again.	
7	Mount the cylinder head cover with the new gasket and tighten evenly.	
8	Fully assemble the engine.	

Step	Activity	Figure
9	Perform a test run. Check the cylinder head cover for tightness.	

## 8.2.7 Maintaining the oil bath filter

### Safety notes

⚠ CAUTION	
	<p><b>Danger of burns.</b></p> <p>There is a danger of burns when working on a hot engine.</p> <ul style="list-style-type: none"> <li>Let the engine cool before maintenance.</li> </ul>
CAUTION	
	<ul style="list-style-type: none"> <li>Do not repair the oil bath filter (weld/solder, etc.) as this may lead to destruction of the filter or damage to the engine.</li> <li>For model with cyclone precleaner: Never add oil to the dust trap.</li> </ul>

### Procedures

The procedure differs depending on how the engine is equipped:

- Procedures for oil bath filter without cyclone precleaner
- Procedures for oil bath filter with cyclone precleaner

### Procedures for oil bath filter without cyclone precleaner

Step	Activity	Figure
1	Remove the oil container (1).	
2	Remove the dirty oil and sludge and clean the container.	
3	Rinse the filter insert (2) in diesel fuel. Before assembling the filter, drip or wipe dry.	
4	Clean the filter housing (3) if it is very dirty.	



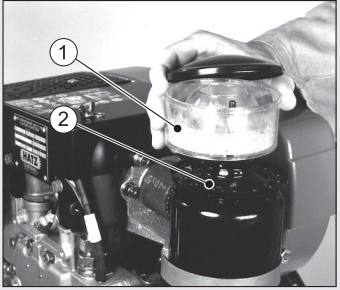

Step	Activity	Figure
5	Fully assembly the filter and prepare it for operation by filling it with oil (see the chapter 7.8.2 <i>Oil level in the oil bath filter (option)</i> , page 46).	

### Procedures for oil bath filter with cyclone precleaner



Step	Activity	Figure
1	Take off the dust collection container (1), empty it and clean it without using liquids.	
2	Also clean the intake opening (2) without liquids.	
3	Fully assemble the cyclone precleaner and tighten with the wing nut.	

## 8.2.8 Clean the cooling air area

### Safety notes

 <b>CAUTION</b>	
	<p><b>Danger of burns.</b></p> <p>There is a danger of burns when working on a hot engine.</p> <ul style="list-style-type: none"> <li>▪ Let the engine cool before maintenance.</li> </ul>
 <b>CAUTION</b>	
 	<p><b>Danger of injury.</b></p> <p>When working with compressed air, foreign bodies may fly into your eyes.</p> <ul style="list-style-type: none"> <li>▪ Wear safety goggles.</li> <li>▪ Never direct the compressed air jet toward people or toward yourself.</li> </ul>

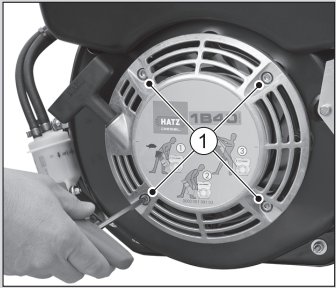
**Procedure**

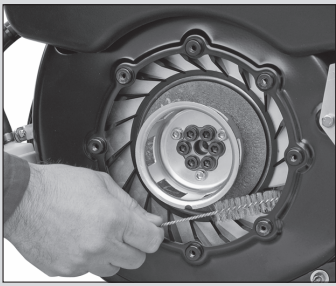
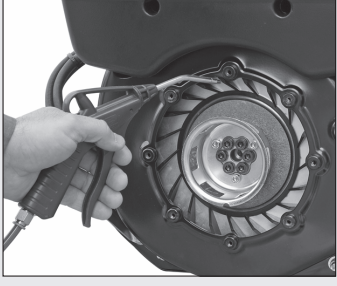
Step	Activity	Figure
<b>Dry contamination</b>		
1	Remove the screws (1).	
2	Take off the recoil start (2) and clean it.	
3	Clean the fan blades with a suitable brush.	
4	Then blow it out with compressed air.	

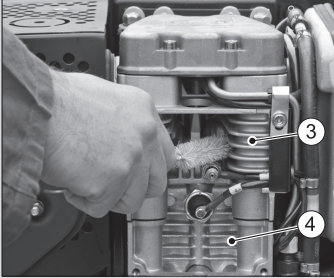
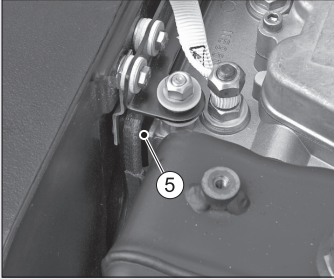
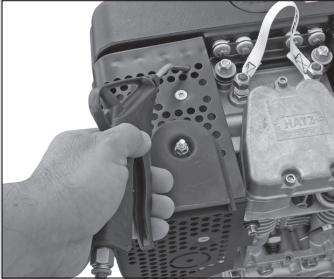
Step	Activity	Figure
5	Also clean the cooling ribs of the cylinder head (3) and cylinder (4) and blow out with compressed air.	
6	<p>Check the air gap (5) for dirt and clean with compressed air if necessary.</p> <p>Note: In 1B20 and 1B27, the air gap (5) is markedly smaller than the gap shown in the figure (size approx. 5 mm).</p>	
7	The element can be checked and cleaned through the holes in the contact guard.	
8	Mount the recoil start (2) again.	
<b>Moist or oily contamination</b>		
1	Contact the HATZ service station.	

## 8.2.9 Check the screw connections

### NOTICE



- Do not retighten the screws for attaching the cylinder head.
- The adjustment screws on the speed regulator and the injection system are secured with locking varnish and are not permitted to be tightened or adjusted.

### Procedure

Step	Activity	Figure
1	Check the condition of all screw connections and ensure that they are tight (exceptions, see note).	
2	Tighten any loose screw connections.	

## 8.2.10 Clean the exhaust screen

### Safety notes



### CAUTION



### Danger of burns.

- There is a danger of burns when working on a hot engine.
- Let the engine cool before maintenance.



### CAUTION



### Danger of injury

- There is a danger of injury when performing cleaning work at the exhaust screen.
- Wear safety gloves.





## Procedures

The exhaust screen can be cleaned in different ways depending on how the engine is equipped:

- Cleaning the exhaust screen in standard models
- Cleaning the exhaust screen in models for rammer operation (1B20 R)

### Cleaning the exhaust screen in standard models

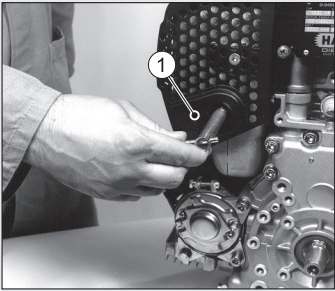
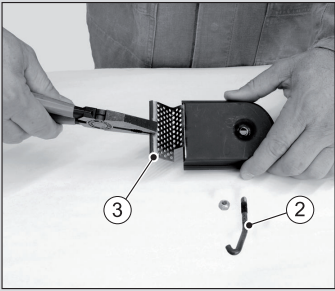
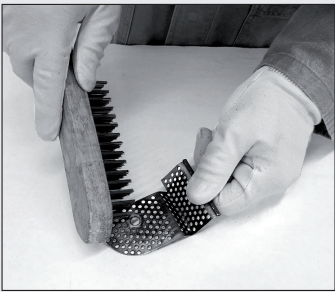

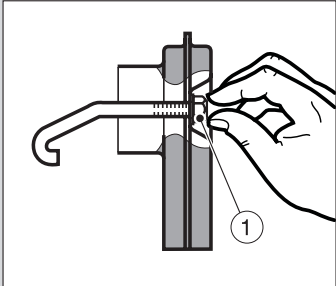
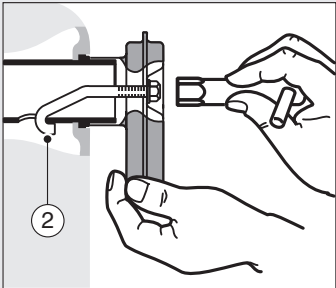
Step	Activity	Figure
1	Release the hex nut and take off the exhaust manifold (1).	
2	Remove the hex nut from the bracket (2) and pull out the screen insert (3).	
3	Remove the deposits in the screen insert with a suitable wire brush.	
4	Check the screen insert for cracks or breakage, and replace if necessary.	
5	Mount the screen insert and bracket again.	

Step	Activity	Figure
6	Tighten the hex nut (1) by approx. one turn.	
7	Insert the exhaust manifold with the bracket (2) into the hole and pull it back to the outside so that the bracket can no longer become unhooked.	
8	Tighten the hex nut.	

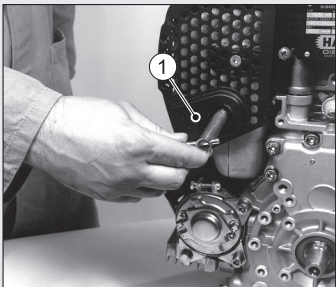
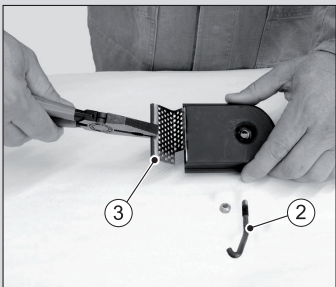
### Clean the exhaust screen in models for rammer operation (1B20 R)

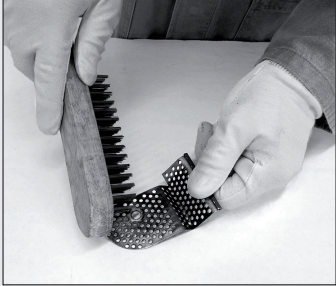
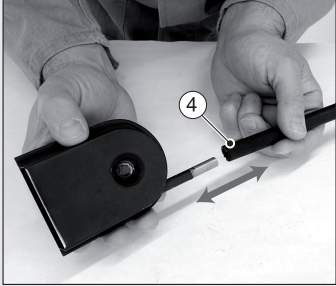
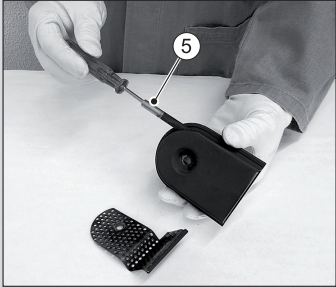

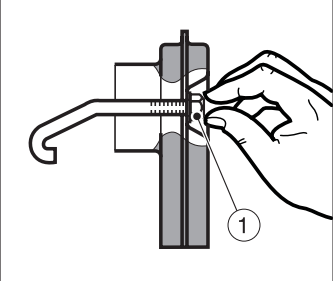
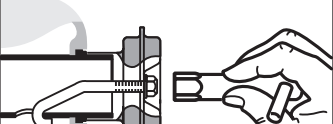
Step	Activity	Figure
1	Release the hex nut and take off the exhaust manifold (1).	
2	Remove the hex nut from the bracket (2) and pull out the screen insert (3).	



Step	Activity	Figure
3	Remove the deposits in the screen insert with a suitable wire brush.	
4	Check the screen insert for cracks or breakage, and replace if necessary.	
5	Pull the hose (4) off of the exhaust manifold.	
6	Check that the pipe connection (5) is clear. Remove deposits using a screwdriver or similar instrument.	
7	Attach the hose again.	
8	Mount the screen insert and bracket again.	

Step	Activity	Figure
9	Tighten the hex nut (1) by approx. one turn.	
10	Insert the exhaust manifold with the bracket (2) into the hole and pull it back to the outside so that the bracket can no longer become unhooked.	
11	Tighten the hex nut.	

## 8.2.11 Changing the fuel filter

### Safety notes

 <b>DANGER</b>	
 	<p data-bbox="348 967 586 991"><b>Fire hazard from fuel</b></p> <p data-bbox="348 1007 1016 1058">Leaked or spilled fuel can ignite on hot engine parts and cause serious burn injuries.</p> <ul data-bbox="348 1070 925 1166" style="list-style-type: none"> <li>▪ Do not spill fuel.</li> <li>▪ No open flames when working on the fuel system.</li> <li>▪ Do not smoke</li> </ul>

<b>⚠ CAUTION</b>	
 	<p><b>Danger of injury</b></p> <p>Repeated contact with diesel fuel can cause chapped and cracked skin.</p> <ul style="list-style-type: none"> <li>▪ Wear safety gloves.</li> </ul>
<b>⚠ CAUTION</b>	
	<p><b>Danger of environmental damage from spilled fuel.</b></p> <p>When the filter is removed, a small amount of fuel is drained as well.</p> <ul style="list-style-type: none"> <li>▪ Collect emerging fuel and dispose of it in an environmentally compatible manner.</li> </ul>
<b>CAUTION</b>	
	<p>Dirt particles can damage the injection system.</p> <ul style="list-style-type: none"> <li>▪ Maintain clean conditions to ensure that dirt does not enter the fuel line.</li> </ul>

### Procedures

The fuel filter can be changed in different ways depending on how the engine is equipped:

- Model with fuel filter in tank
- Model with double fuel filter system
- Model with external fuel filter

### Model with fuel filter in tank

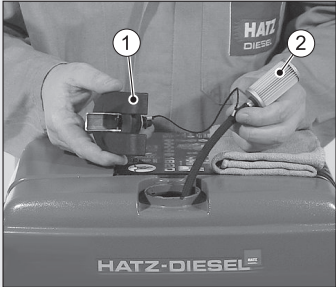
Step	Activity	Figure
1	Open the fuel cap (1) and pull the fuel filter (2) out of the tank by the cord.	

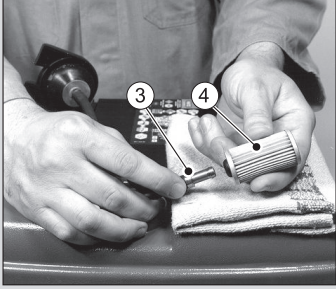
Step	Activity	Figure
2	Pull the fuel feed line (3) off of the fuel filter (4) and insert a new filter.	
3	Insert the fuel filter back into the tank.	
4	Close the fuel cap. The fuel system is bled automatically.	

### Model with double fuel filter system

#### NOTICE

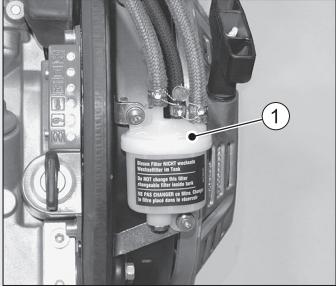

- The advantage of this system is that dirt particles that may enter the fuel line during a filter change are captured by the downstream outside filter and are therefore unable to endanger the injection system.
- **This outside filter is NOT permitted to be changed. Only change the fuel filter in the tank.**

Step	Activity	Figure
1	Do <b>not</b> change the maintenance-free outside filter (1).	

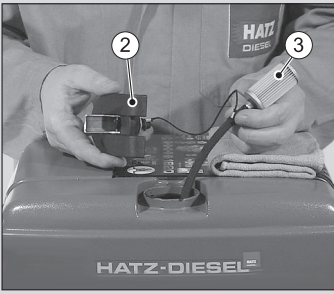
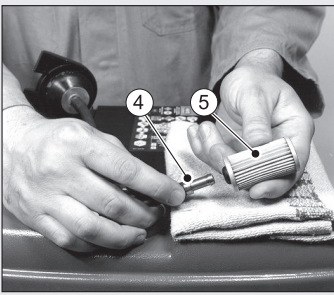
Step	Activity	Figure
2	Open the fuel cap (2) and pull the fuel filter (3) out of the tank by the cord.	
3	Pull the fuel feed line (4) off of the fuel filter (5) and insert a new filter.	
4	Insert the fuel filter back into the tank.	
5	Close the fuel cap. The fuel system is bled automatically.	

### Model with external fuel filter

#### NOTICE

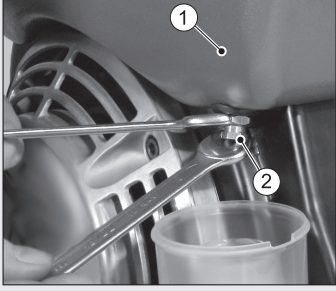
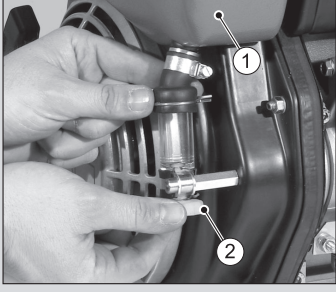
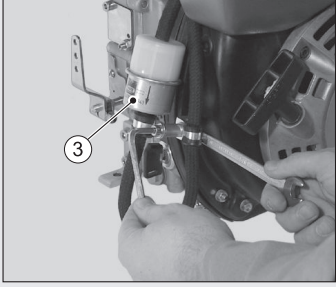
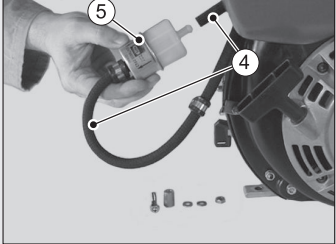

In the model with an external fuel filter, there is no fuel filter in the tank.

Step	Activity	Figure
1a	<p><b>Water separator without window:</b></p> <p>Empty the fuel tank (1). Open the screw (2) and let the fuel drain into a clean container.</p> <p>The fuel can be used again later.</p>	
1b	<p><b>Water separator with window:</b></p> <p>Empty the fuel tank (1). Open the screw (2) and let the fuel drain into a clean container.</p> <p>The fuel can be used again later.</p>	
2	<p>Unscrew the fuel filter (3) from the holder.</p>	
3	<p>Place a suitable container under the fuel filter (3) to collect the remaining fuel.</p>	
4	<p>Pull the fuel line (4) off of the fuel filter (5) on both sides and insert a new filter.</p> <p>Observe the flow-through direction (arrows).</p>	

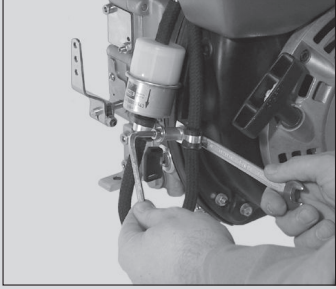

Step	Activity	Figure
5	Attach the fuel filter to the holder.	
6	Fill the fuel tank with diesel fuel (see the chapter 7.6 <i>Refueling</i> , page 40). The fuel system is bled automatically.	
7	Check the fuel filter and lines for tightness after a brief trial run.	

### 8.2.12 Maintaining the dry air filter

#### NOTICE



- Immediately clean the filter cartridge if the maintenance display appears at maximum speed.
- Renew the filter cartridge after a use period of 500 operating hours.

#### Procedures

The dry air filter is maintained in a series of steps that depend on how the engine is equipped:

- Check the air filter maintenance indicator (additional equipment).
- Installing and removing the filter cartridge

#### Checking the air filter maintenance indicator (additional equipment)

In a dusty environment, check the rubber bellow several times a day.

Step	Activity	Figure
1	Bring the engine briefly to maximum speed.	

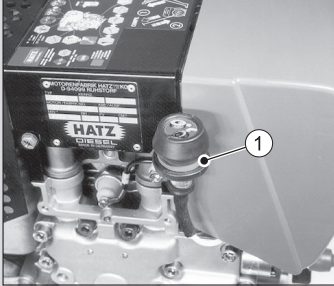
Step	Activity	Figure
2	Maintain the dry air filter when the rubber bellow contracts and covers the green field (1).	



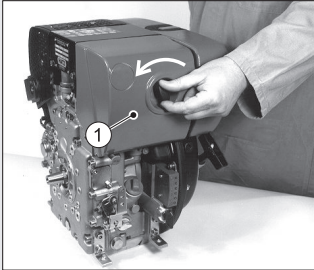
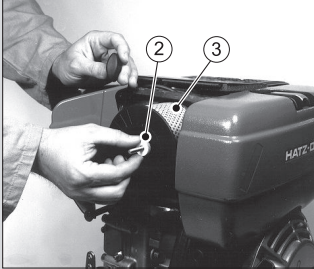
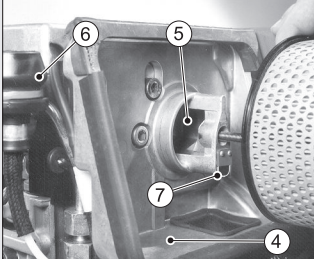

**Installing and removing the filter cartridge**

Step	Activity	Figure
1	Unscrew the air filter cover(1).	
2	Unscrew the knurled nut (2) and remove the air filter cartridge (3).	
3	Clean the filter housing (4) and cover for the air filter. Ingress of dirt or other foreign bodies into the intake opening (5) of the engine absolutely must be avoided.	

Step	Activity	Figure
4	In the model with an air filter maintenance display (6), check the condition and cleanliness of the valve shim (7).	
5	The air filter cartridge either needs to be replaced, or cleaned or checked depending on the degree of contamination (see the chapter <i>8.2.13 Checking and cleaning the air filter cartridge</i> , page 75).	
6	Assemble in reverse order.	

### 8.2.13 Checking and cleaning the air filter cartridge

#### Safety notes

 <b>CAUTION</b>	
 	<p><b>Danger of injury.</b></p> <p>When working with compressed air, foreign bodies may fly into your eyes.</p> <ul style="list-style-type: none"> <li>▪ Wear safety goggles.</li> <li>▪ Never direct the compressed air jet toward people or toward yourself.</li> </ul>
<b>NOTICE</b>	
	<ul style="list-style-type: none"> <li>▪ The pressure must not exceed 5 bar.</li> <li>▪ Even minor damage in the areas of the sealing surface, filter paper or filter cartridge makes it impossible to reuse the filter cartridge.</li> </ul>

#### Checking and cleaning the air filter cartridge

Step	Activity	Figure
	<b>Dry contamination</b>	

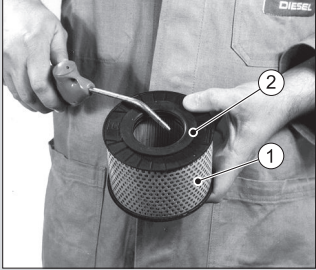
Step	Activity	Figure
1	Blow out the filter cartridge (1) with dry compressed air from the inside to the outside until dust no longer emerges.	
2	Check the sealing surface (2) of the filter cartridge for damage.	
3	Check the filter cartridge for cracks in the filter paper and other damage by holding it against the light at a slant or letting light from a lamp shine through it.	
4	Replace the filter cartridge if necessary (see note).	
<b>Moist or oily contamination</b>		
1	Renew the filter cartridge.	

## 9 Faults

### 9.1 Troubleshooting

#### Troubleshooting notes

If the cases listed below have been worked through but the fault continues to persist, please contact your nearest **HATZ service station**.

Type of fault	Possible causes	Remedy	Chapter
The engine either hesitates or does not start at all, but can be turned easily as usual.	Speed control lever in stop or idle position. Stop pin in STOP position.	Position the speed control lever in the "START" operating position.	
		Move the stop pin by pulling it lightly into the operating position.	<i>7.5.1 Switching off the engine (mechanical), page 37</i>
	No fuel at the injection pump.	Add fuel. Systematically check the entire fuel supply:	<i>7.6 Refueling, page 40</i>
		If this does not yield results: - Check the feed line to the engine. - Check the fuel filter.	<i>8.2.11 Changing the fuel filter, page 68</i>
	Insufficient compression: ▪ Wrong tappet clearance.	Check the tappet clearance and adjust if necessary.	<i>8.2.6 Check and set the tappet clearance, page 56</i>
▪ Cylinder and/or piston ring wear.	Contact the HATZ service station.		
	Injection nozzle is not functional.	Contact the HATZ service station.	
At low temperatures	Temperature below start limit temperature.	Activate the pre glow unit (additional equipment).	<i>7.4.2 Starting the engine with an electric starter, page 35</i>

Type of fault	Possible causes	Remedy	Chapter
	The machine is not uncoupled.	If possible, separate the engine from the machine by uncoupling it.	
	Pre glow system is faulty (additional equipment)	Contact the HATZ service station.	
	Fuel gelled due to insufficient cold resistance.	Check whether the fuel that emerges from the detached fuel feed line directly at the injection pump is clear and not cloudy. If the fuel has gelled, either warm the engine or drain the entire fuel supply system. Fill with a temperature-resistance fuel mixture.	4.2 Fuel, page 24 7.6 Refueling, page 40 8.2.11 Changing the fuel filter, page 68
	Starting speed below 400 rpm : <ul style="list-style-type: none"> <li>▪ Oil too viscous.</li> </ul>	Change the engine oil and add oil of the right viscosity class.	7.8 Checking the oil level and adding oil if necessary, page 44
	<ul style="list-style-type: none"> <li>▪ Insufficiently charged battery.</li> </ul>	Check the battery and contact the service center if necessary.	3.2.4 Electrical equipment, page 18
When equipped with a stop magnet or an automatic electrical switch-off mechanism (additional equipment)	The stop magnet is not functional and/or irregularities in the electrical equipment.	Contact the HATZ service station.	
The engine starts but then fails to continue running.	The speed control lever is not sufficiently set to the Start direction.	Set the lever to the Start position.	7.4 Starting the engine, page 32

Type of fault	Possible causes	Remedy	Chapter
	Machine is not uncoupled.	If possible, separate the engine from the machine by uncoupling it.	
	Fuel filter is clogged.	Change the fuel filter.	<b>8.2.11</b> <i>Changing the fuel filter, page 68</i>
With automatic electrical switch-off mechanism (additional equipment)	Stop signal from monitoring elements that are associated with the automatic switch-off.	Identify the triggering monitoring element and eliminate the source of the fault, or contact the HATZ service station.	
	Monitoring element for: <ul style="list-style-type: none"> <li>▪ Oil pressure too low.</li> <li>▪ Engine temperature too high.</li> </ul>	Check the engine for: <ul style="list-style-type: none"> <li>Engine oil filling level</li> <li>Contamination of the cooling air guides or another impairment of the cooling system.</li> </ul>	<b>7.8</b> <i>Checking the oil level and adding oil if necessary, page 44</i> <b>8.2.8</b> <i>Clean the cooling air area, page 61</i>
	Faulty AC alternator.	Contact the Hatz service station.	
	Fault signal from the overvoltage and polarity protection system in the voltage regulator: <ul style="list-style-type: none"> <li>▪ Battery and/or other cable connections are incorrectly connected.</li> <li>▪ Loose cable connections.</li> </ul>	Check the electrical equipment and their components.	<b>3.2.4</b> <i>Electrical equipment, page 18</i>

Type of fault	Possible causes	Remedy	Chapter
The starter does not switch on and the engine does not turn.	Irregularities in the electrical equipment: <ul style="list-style-type: none"> <li>▪ Battery and/or other cable connections are incorrectly connected.</li> <li>▪ Cable connections are loose and/or oxidized.</li> <li>▪ Battery is faulty and/or not loaded.</li> <li>▪ Faulty starter.</li> <li>▪ Faulty relay, monitoring elements, etc.</li> </ul>	Check the electrical equipment and their components. Contact the Hatz service station.	3.2.4 <i>Electrical equipment, page 18</i>
Engine switches off spontaneously during operation.	Fuel supply is interrupted:		7.6 <i>Refueling, page 40</i> 8.2.11 <i>Changing the fuel filter, page 68</i>
	<ul style="list-style-type: none"> <li>▪ The tank ran out of fuel during operation</li> </ul>	Add fuel	
	<ul style="list-style-type: none"> <li>▪ Fuel filter is clogged</li> </ul>	Change the fuel filter.	
	<ul style="list-style-type: none"> <li>▪ Tank vent is clogged.</li> </ul>	Ensure that the tank is sufficiently vented.	
	<ul style="list-style-type: none"> <li>▪ Air in the fuel system.</li> </ul>	Check the fuel system for air ingress. Check the bleed valve.	
<ul style="list-style-type: none"> <li>▪ Mechanical faults.</li> </ul>	Contact the Hatz service station.		



Type of fault	Possible causes	Remedy	Chapter
With automatic electrical switch-off mechanism (additional equipment)	Stop signal from monitoring elements that are associated with the automatic switch-off.	Identify the triggering monitoring element and eliminate the source of the fault, or contact the HATZ service station.	
	Monitoring element for: <ul style="list-style-type: none"> <li>▪ Oil pressure too low.</li> <li>▪ Engine temperature too high.</li> </ul>	Check the engine for: <ul style="list-style-type: none"> <li>Engine oil filling level</li> <li>Contamination of the cooling air guides or another impairment of the cooling system.</li> </ul>	<i>7.8 Checking the oil level and adding oil if necessary, page 44</i> <i>8.2.8 Clean the cooling air area, page 61</i>
	Faulty AC alternator.	Contact the Hatz service station.	
	Fault signal from the overvoltage and polarity protection system in the voltage regulator: <ul style="list-style-type: none"> <li>▪ Battery and/or other cable connections are incorrectly connected.</li> <li>▪ Loose cable connections.</li> </ul>	Check the electrical equipment and their components.	<i>3.2.4 Electrical equipment, page 18</i>
The engine loses power and speed.	The fuel supply is impaired		<i>7.6 Refueling, page 40</i> <i>8.2.11 Changing the fuel filter, page 68</i>
	<ul style="list-style-type: none"> <li>▪ The tank ran out of fuel during operation.</li> <li>▪ Fuel filter is clogged.</li> <li>▪ Tank vent is clogged.</li> </ul>	Add fuel. Change the fuel filter. Ensure that the tank is sufficiently vented.	

Type of fault	Possible causes	Remedy	Chapter
	<ul style="list-style-type: none"> <li>▪ Air in the fuel system.</li> </ul>	Check the fuel system for air ingress. Check the bleed valve.	
	<ul style="list-style-type: none"> <li>▪ The speed adjustment lever does not stay in the desired position.</li> </ul>	Block the speed adjustment.	
The engine loses power and speed, and black smoke emerges from the exhaust.	Air filter is dirty.	Clean the air filter or renew it.	8.2.12 <i>Maintaining the dry air filter, page 73</i>
	Tappet clearance not OK.	Adjust the tappet clearance.	8.2.6 <i>Check and set the tappet clearance, page 56</i>
	Injection nozzle is not functional.	Contact the Hatz service station.	
Engine becomes very hot. Indicator lamp for the cylinder head temperature (additional equipment) lights up.	Too much engine oil in the engine.	Drain the engine oil to the upper mark of the dipstick.	7.8 <i>Checking the oil level and adding oil if necessary, page 44</i>
	Inadequate cooling: <ul style="list-style-type: none"> <li>▪ Contamination in the entire area of the cooling air guides.</li> </ul>	Clean the cooling air area.	
	<ul style="list-style-type: none"> <li>▪ Incompletely closed air baffle plates.</li> </ul>	Check the cooling air baffle plates and shafts for completeness and good sealing properties.	

Type of fault	Possible causes	Remedy	Chapter
Condensate emerges from the exhaust silencer.	Operation under no load for an extended period.	Operate the machine at a load of approx. 70 % until the exhaust outlet is dry again.	

## 9.2 Emergency start

If an electrical fault signal occurs, the automatic switch-off locks the shutoff valve (1) and thereby stops the fuel supply to the injection pump – the engine switches off. Also, a fault in the electrical equipment can cause the engine to switch off.

If this occurs at a critical location, such as at a railroad crossing or intersection, an emergency start can be activated.

### Function of shutoff valve

Starting key settings:

**Set the starting key to "I".**

The shutoff valve (1) is unlocked electrically. The fuel supply is enabled, the engine is ready to start.

**Set the starting key to "0".**

The shutoff valve (1) is switched off. The fuel supply is blocked and the engine switches off.

### Electrical automatic shutoff (additional equipment)

The distinguishing feature of the electrical automatic shutoff is brief flashing of all indicators after turning the starting key to position "I".

#### NOTICE



Note - If the engine stops again immediately after starting, or stops independently during operation, this is an indication that a monitoring element of the automatic shutoff has been activated (see the chapter 9.1 *Troubleshooting*, page 77).

### Safety notes



#### CAUTION



**Danger when switching off the engine from the emergency operation mode.**

During the emergency operation mode, the engine can only be switched off with the starting key if the emergency start lever is first returned to its home position **in a clockwise direction**.

CAUTION	
	<p><b>Danger of later engine damage.</b></p> <p>The monitoring components (oil pressure, charge control and engine temperature) are deactivated in emergency operation.</p> <ul style="list-style-type: none"> <li>▪ The oil level must be checked before the emergency operation phase.</li> </ul>
NOTICE	
	<p>If the emergency operation mode is used, the risk transfers to the operator (<b>the Motorenfabrik HATZ does not accept liability in this case</b>).</p> <ul style="list-style-type: none"> <li>▪ Immediately after the emergency operation phase, determine the cause of the fault.</li> <li>▪ Have the <b>Hatz service station</b> supply the emergency start lever with a new lead seal.</li> </ul>

**Overview**

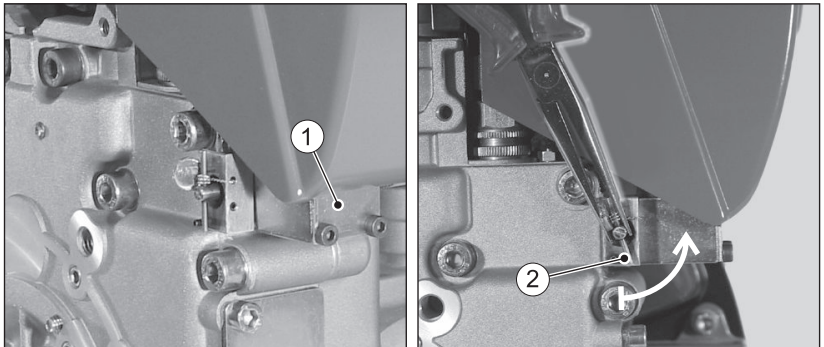

Pos.	Designation
1	Fuel shutoff valve (additional equipment)
2	Emergency start lever

**Procedure**

Step	Activity
1	<p>Using suitable pliers, turn the emergency start lever (2) counterclockwise by at least 90° (seal wire tears).</p> <p>The emergency start level is now located in the start position, and the shutoff valve (1) is mechanically unlocked.</p>

Step	Activity
2	Start the engine with the electric starter or recoil start (see the chapter <i>7.4.1 Starting the engine with recoil start (up to -6 °C)</i> , page 33).
3	Turn the emergency start lever back to the stop in a clockwise direction. Otherwise, it will not be possible to switch off the machine using the starting key.

## 10 Storage and disposal

### 10.1 Storing the machine

#### General information

<b>NOTICE</b>	
	<p><b>Comply with the safety chapter!</b></p> <p>Follow the basic safety instructions in the chapter 3 <i>Safety</i>, page 7.</p>

#### Storing the machine for a lengthy period

Take the following measures if you intend to take the machine out of service for a lengthy period:

Step	Activity
1	After the machine has cooled down, cover it to protect it against dust and store it in a dry and clean place.

The new engine can normally be stored for up to 1 year.

The protection lasts up to approx. 6 months at very high humidity and with sea air.

If the storage time is longer, please contact the nearest **Hatz service**.

### 10.2 Disposing of the machine

#### Disposal information

Dispose of the machine (including machine parts, engine oil and fuel) according to the local disposal regulations and the environmental laws in the country of use.

Because of the danger of possible environmental damage, only permit an approved specialist company to dispose of the machine.

<b>NOTICE</b>	
	<p>When the machine has reached the end of its lifecycle, ensure that it is disposed of safely and properly, especially parts and substances that can be dangerous to the environment. These also include fuel, lubricants, plastics and batteries (if present).</p> <ul style="list-style-type: none"> <li>▪ Do not dispose of the battery with the household trash.</li> <li>▪ Dispose of the battery at a collection point for possible recycling.</li> </ul>

# 11 Installation declaration

## Extended manufacturer's declaration / Declaration of Incorporation EC Machinery Directive 98/37/EC or 2006/42/EC\*)

The manufacturer: **Motorenfabrik Hatz GmbH & Co.KG**  
**Ernst-Hatz-Straße 16**  
**D-94099 Ruhstorf a. d. Rott**

hereby declares that the incomplete machine: product description: **Hatz diesel engine**  
 Type designation and as of serial number:  
**1B20=10031; 1B20 NON EPA=30031; 1B20V=11121; 1B20V NON EPA=30121; 1B20R=14410;**  
**1B27=12510; 1B27 NON EPA=30810;**  
**1B30=10125; 1B30 NON EPA=30225; 1B30V=11216; 1B30V NON EPA=30316;**  
**1B40=11014; 1B40 NON EPA=30414; 1B40V=11714; 1B40V NON EPA=30514;**  
**1B50=12411; 1B50 NON EPA=30611; 1B50V=12611; 1B50V NON EPA=30711**

satisfies the following basic safety and health protection requirements in acc. with Annex I to the above-mentioned Directive.

- Annex I, General principles no. 1
  - Nr. 1.1.2., 1.1.3., 1.1.5., 1.2.1., 1.2.2., 1.2.3., 1.2.4.1., 1.2.4.2., 1.3.1., 1.3.2., 1.3.3., 1.3.4., 1.3.7., 1.3.9., 1.4.1., 1.5.1., 1.5.3., 1.5.8., 1.5.9., 1.6.1., 1.6.2., 1.6.4., 1.7.

All relevant basic safety and health protection requirements down to the interfaces described  
 in the operating manual  
 in the enclosed data sheets  
 in the enclosed technical documents  
 have been complied with.

The special technical documents in acc. with Annex VII B of the Directive 2006/42/EC have been prepared \*\*).

Conformity with the provisions of the following, other EC Directives, i.e.  
 - **2004/108/EG Electromagnetic Compatibility (EMC)**, dated 15.12.2004

The following standards have been used (completely or partially):  
 - EN 1679-1: 051998      - EN ISO 12100-1: 042004      - EN ISO 13857: 062008  
 - EN ISO 14121-1: 122007      - EN ISO 12100-2: 042004

I will submit the above-mentioned specific technical documents electronically to the competent government authority, if applicable\*\*)

The Operating Manual has been enclosed to the incomplete machine and the Assembly Instructions have been provided to the customer electronically together with the order confirmation.

Commissioning has been prohibited until it has been established, if applicable, that the machine into which the above-mentioned incomplete machine is to be incorporated, satisfies the provisions of the Machinery Directive.

Wolfgang Krautloher / see "Manufacturer"  
 Name / address of EC documentation officer \*\*)

29/10/2009

Krautloher / Directives official

Date

Signature and information on the undersigned

  
 Signature

\*) The machine satisfies the substantial requirements of both directives 98/37/EC shall apply until 28.12.2009; 2006/42/EC shall apply as of 29.12.2009  
 \*\*) applies only to the Directive 2006/42/EC

**Motorenfabrik Hatz GmbH & Co. KG**

Ernst-Hatz-Str. 16  
94099 Ruhstorf a.d. Rott  
Deutschland  
Tel. +49 8531 319-0  
Fax +49 8531 319-418  
marketing@hatz-diesel.de  
www.hatz-diesel.com

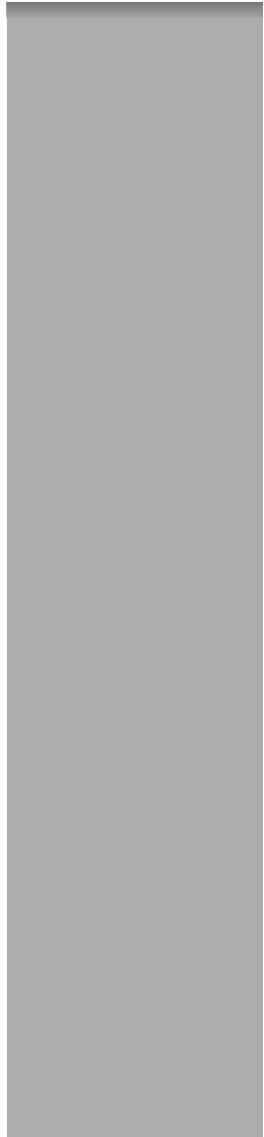

**CREATING POWER SOLUTIONS.**